

TOMOE EXCELLENCE IN HYDRODYNAMICS

Triple Offset Butterfly Valves

150/300/600/900/1500lb

Installation & Maintenance Manual - Tritec Valves

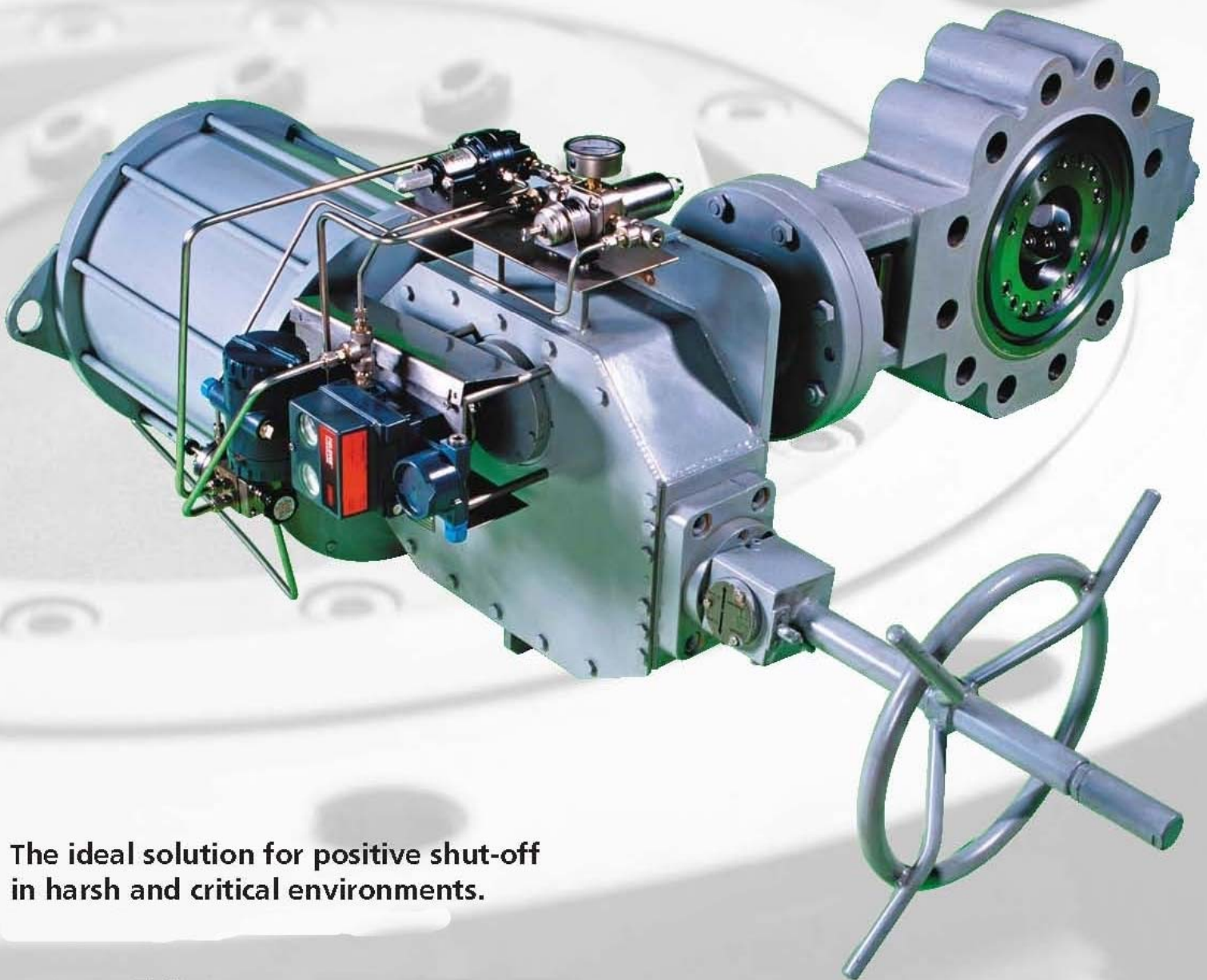

**The ideal solution for positive shut-off
in harsh and critical environments.**

Index

1. Exploded View of Valve.....	Page 4
2. Storage.....	Page 5
3. Transport.....	Page 5
4. Handling and Lifting.....	Page 6
5. Installation.....	Page 7 – 10
6. Maintenance.....	Page 11 – 19
7. Product Warranty.....	Page 21 – 22

1. Exploded View of Valve

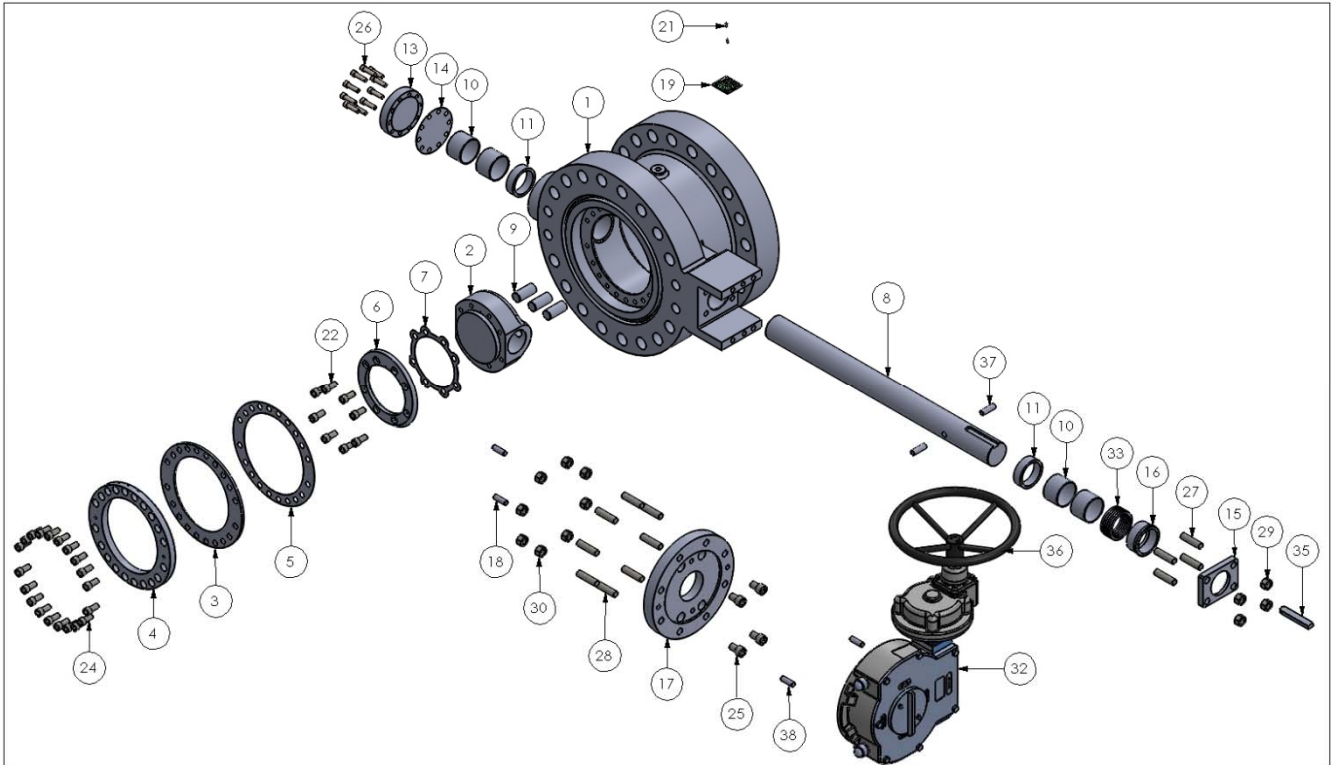

Item	Component	Item	Component
1	Body	20	---
2	Disc	21	Nameplate Rivet
3	Body Seat	22	Disc Seal Screw
4	Body Seat Retaining Ring	23	---
5	Body Seat Gasket	24	Body Seat Screw
6	Disc Seal	25	Mounting Plate Screw
7	Disc Seal Gasket	26	End Cover Screw
8	Shaft	27	Gland Screw
9	Shaft Pin	28	Operator Screw
10	Bearing	29	Gland Nuts
11	Thrust Ring	30	Operator Nut
12	---	31	---
13	End Cover	32	Operator
14	End Cover Gasket	33	Gland Packing (Braided)
15	Gland Plate	34	---
16	Gland Plate Spigot	35	Key
17	Mounting Plate	36	Operator Hand wheel
18	Dowel Pin	37	Anti-blowout Device
19	Nameplate	38	---

Introduction

This instruction manual provides information on the storage, installation, operating and maintenance of the Trittec range of triple offset valves. The Trittec valves are designed and manufactured to operate in a variety of environments under extremes of pressure and temperature with minimal maintenance. However, due to the arduous conditions that these valves may be subjected to, routine maintenance may be required. The manual is only a general guide and should not be used for any other purpose.

2. Storage After Receipt

- a. Valves should be stored in a closed, clean and dry storage room in a cool temperature between -10°C and +60°C with humidity lower than 70% until ready for installation.
- b. It is recommended that the valves are left in the original packaging until ready for installation.
- c. Do not remove the protective covers until you are ready to install the valves.
- d. Valves may be painted according to the client specification. However, the gasket sealing faces, RTJ groove and weld ends are shipped uncoated, as this will impair sealing performance. For long periods of storage (more than 4 weeks) it is recommended to coat the surfaces of ferrous materials with a rust preventative – contact Tomoe Valve Ltd for advice if required.
- e. If the valves are removed from the original packaging care should be taken to protect the valve and actuator from excessive loads. Unpacked valves should not be stacked.
- f. Valves may be supplied as ‘Commercially Clean’ or ‘For Oxygen Service’. The valve packaging will be marked accordingly and sealed in suitable packaging. The valves should be left in the sealed packaging until ready for installation and should be treated in the same manner as other equipment in the respective process.

3. Transport Protection

- a. All valves will be despatched with wooden or plastic covers attached to the flange faces or weld end to protect the sealing surfaces and internal trim.
- b. Normally the valve disc will be set in the fully closed position. The only exception to this will be when the valve is fitted with a ‘fail open’ actuator.
- c. Prior to despatch all valves are suitably packed using pallets or crates.

IMPORTANT

Machinery Directive 2006/42/EC Declaration of Incorporation

Tomoe Trittec valves must not be put into service until the machinery into which they are to be incorporated has been declared in conformity with the provisions of the machinery directive

Tomoe Trittec valves must not be used as safety critical components (Emergency Shutdown Valves) within the meaning of the Machinery Directive without prior notification to Tomoe Valve Ltd

4. Valve Handling and Lifting

- Valve / Actuator assemblies should be lifted using slings(s) of the correct lifting capacity. (For the weight of the Valve / Actuator assembly please refer to the general arrangement drawing for the respective serial number as listed on the supplied test certificate pack included with the product shipment).
- The sling(s) must support the Valve in at least two points and use an appropriate stud and nut to secure the sling to the valve as per the following diagrams.

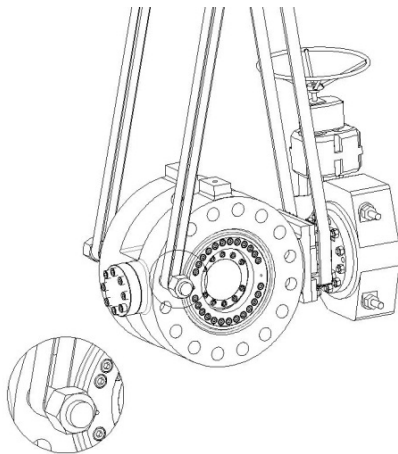

Fig. 1a Gearbox Valve

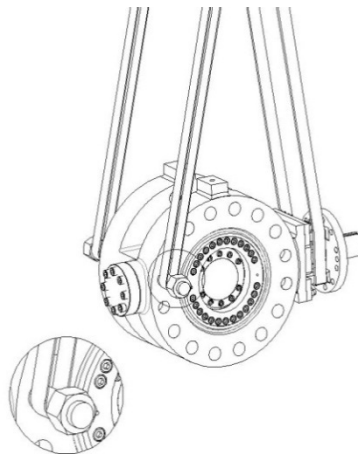

Fig. 1b Bare shaft Valve

Actuated Valves

Due to the numerous actuator types, sizes and weights, a generic lifting diagram is not available. The best slinging method for these valves should be determined on site. Please ensure:

- That slings have the correct lifting capacity for the valve and actuator assembly.
- To avoid damage, ensure both the valve and actuator are sufficiently supported at all times. I.e. do not lift the entire assembly by the actuator or valve separately.
- DO NOT** lift the assembly using the valve or actuator lifting points. The location and rating of these points have not been designed to take into account the size and weight of the other.



IMPORTANT

Only properly trained personnel should carry out handling and lifting of the assembly.

These instructions will not apply to an installation that may require the valve in a different orientation; this should only be carried out by qualified personnel.

Eyebolts are not provided as standard however if included eyebolts are only rated for the individual items and must NOT be used to lift a Valve and Actuator assembly

When using slings do NOT sling through the bore of the valve as this may cause damage to the internal sealing components.

5. Installation

5.1 Valve Inspection Prior to Installation

- The valve sealing surfaces (e.g. raised face) and the valve internals should be examined prior to installation. If any damage is evident please contact Tomoe Valve for advice before installing the valve.
- Check valve nameplate (Item 19) to confirm materials of construction and product standards are correct for the intended service and as specified. (see fig. 2a and 2b)
- Confirm Gland Packing adjustment nuts (Item 29) cannot be adjusted by hand.

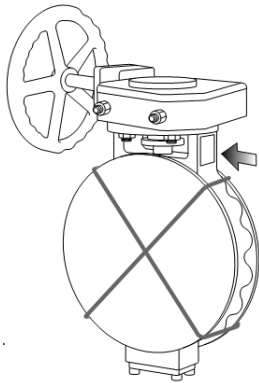

Fig. 2a



Fig. 2b

5.2 Installation

- The valve is designed to seal against bi-directional flow. However enhanced sealing performance will be achieved with the upstream flow against the shaft side of the disc. This 'preferred flow direction' is shown on the valve nameplate (Item 19) attached to the valve body. (see fig. 2b)
- The valve may be installed in the pipeline with the valve shaft in a horizontal, vertical or intermediate position. Where possible it is recommended that the shaft is positioned horizontally as this helps to prevent any dirt or process fluid collecting in and around the bearing cavity. (see fig. 2c)



IMPORTANT

Only properly trained personnel should carry out handling and lifting of the valve or valve assembly – please refer to section 3, Valve Handling & Lifting.

Prior to installation the pipeline should be clear of dirt, welding residue and any other foreign matter that could damage the valve internals.

Ensure the valve is in the fully closed position prior to installation to avoid the risk of damaging the sealing surfaces.

Ensure that suitably rated gaskets are used upon installation into the pipeline.

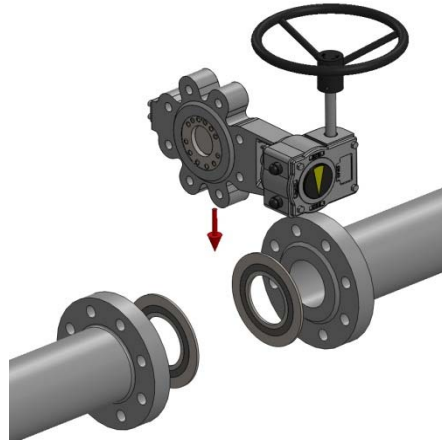

Fig. 2c

5.3 Operator fitting instructions for installation of bare shaft valves

- 150Lb / 300Lb – Shim Fitted on 20" Valves and above
- 600Lb / 900Lb / 1500Lb – Shim Fitted on 6" Valves and above
- Double Flanged Long Pattern Valves shims are secured with tie cables and NOT a stud and nut
- Double Block and Bleed Valves are not supplied with a thrust shim as they are not supplied in bare shaft configuration

The above specified ranges of bare shaft valves are supplied fitted with a thrust gap shim. The purpose of the shim is to prevent damage to the valve seat when fitting the actuator.

The design of the shim is such that the valve cannot be fitted in-line with the shim still attached to the valve. (See fig. 3: Shim in Red)

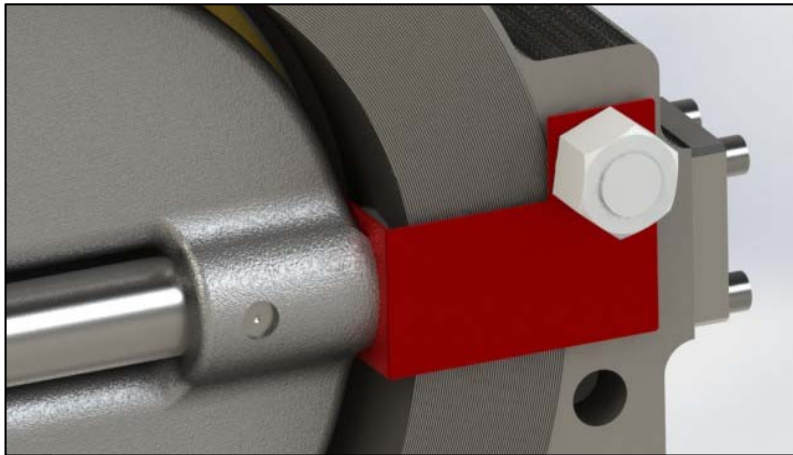

Fig. 3

- a. Ensure the thrust gap shim is fitted. If the shim is missing contact Tomoe Valve for advice.
- b. Ensure the base of the actuator, mating face of the mounting bracket and actuator shaft bore are free from dirt and swarf.
- c. Check number and size of holes on actuator and mounting plate match each other.
- d. The valve disc (except when fitting a fail open actuator) should be in the closed position.
- e. The actuator must not be forced onto the valve shaft as this may damage the valve. Ensuring the shaft and actuator shaft bore are clean and free from burrs should be sufficient to allow the actuator to be fitted with relative ease. The use of a suitable lubricant applied to the shaft is also acceptable.
- f. Once fitted the actuator should be bolted in position with the actuator studs and nuts.
- g. Once the actuator is secured the thrust gap shim can be unbolted and removed.



IMPORTANT

Leave shim in place while fitting operator

DO NOT operate valve with shim fitted

If using a test operator before fitting an as built unit please be sure to re-fit the shim prior to fitting the as built operator

Valve(s) supplied with long pattern body configuration still use the same shim but they are affixed to the valve using cable ties not a nut and as shown in Fig 3.

Tomoe Valve Ltd do not supply dowel pins for actuator location assembly unless requested at the order stage

5.3.1 Setting of stop Position for Gearbox Operator

- a. After fitting the actuator to the valve the stop screws should be adjusted to suit the open and shut positions.
- b. For powered actuation it is normal to set the stops on the powered control, the manual actuator stop screws should then be adjusted into the quadrant stop pad and rotated back one half turn. The manual stop screws are then only contacted in the event of powered limit switch failure
- c. Apply sealant of P.T.F.E. tape to stop screw threads (*) prior to adjustment, then tighten the locknuts once set

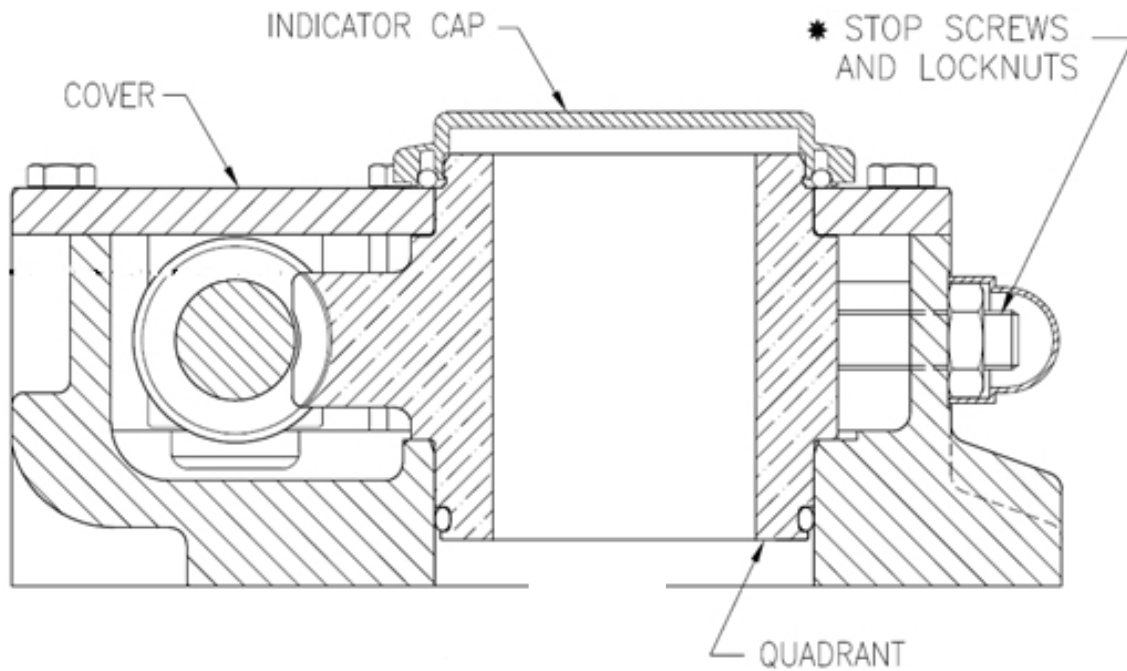

Fig. 4



IMPORTANT

If the gearbox operator has a different configuration to the model shown in Fig. 4 please contact Tomoe Valve Ltd for further advise.

Please refer to the general arrangement drawing supplied with the valve for valve sealing torque

6. Maintenance

Any maintenance or repair work carried out on Tritec valves should be performed by a Tomoe valve technician or approved representative – failure to do so may result in the supplied product warranty being invalid.

Whenever maintenance is to be carried out it is important to have a copy of the relevant valve GA drawing. The GA drawing contains important information such as torque settings and part numbers for valve spares. A copy of the GA drawing is supplied with the valve however please contact Tomoe Valve Ltd if another copy is required or to confirm torques or if there is any doubt. Prior to commencing work we recommend reading the relevant parts of this manual and the GA drawing to familiarise yourself with the valve components and necessary procedure(s) to complete the maintenance.

6.1 List of Recommended Spare Parts

The following items are the recommended field replaceable spare parts (per valve). All other components should only be replaced by Tomoe Valve or an authorised representative. When requesting spares it is important that the relevant valve serial number (located on the valve nameplate – see fig 2b) is supplied to Tomoe. This ensures that the correct parts are supplied for any particular valve.

IMPORTANT

Throughout this manual the valve components will be identified with item numbers (e.g. Body – Item 1). The item numbers can be cross-referenced against the numbers shown on the exploded valve view in section 6.

Whenever torques are mentioned please refer to the correct general assembly drawing for the valve serial no as indicated on the valve nameplate – the general assembly drawing will indicate all required torques for each respective item as described in this manual

Item	Description	Quantity (per valve)
3	Body Seat	1
5	Body Seat Gasket	1
6	Disc Seal	1
7	Disc Seal Gasket	1
14	End Cover Gasket	1
33	Gland Packing (Braided)	5

6.2 Adjustment of Gland Packing

The Tritec valves are supplied with adjustable gland packing that is packed for immediate use and can be adjusted without having to remove the operator. During service (particularly on high cycling applications) it may be necessary to tighten the gland nuts (Item 29).

- a. Where possible the gland nuts should be tightened equally whilst the valve is still pressurised (Only perform this work if authorised by the relevant site Permit to Work). This will allow you to see when the gland stops leaking.
- b. Each nut should only be tightened a maximum of two complete turns before tightening the next nut that is diagonally opposite (This ensures even loading on the gland plate).
- c. Continue to tighten the all the nuts until the gland stops leaking whilst ensuring the gland plate is parallel to the valve body. Cycle the valve a few times and check for leaks.
- d. If the gland packing continues to leak after tightening or the amount of tightening required is excessive, contact Tomoe Valve for advice.



IMPORTANT

Be careful not to over tighten the gland nuts as this may cause the gland packing to 'grip' the valve stem and create excessive friction. Excessive friction will impair the valves performance and in extreme cases may prevent the stem from rotating.

6.3 Replacement of Gland Packing

6.3.1 Removal of Existing Gland Packing

- a. Ensure the valve is de-pressurised and that the necessary authorisation is in place to work on the equipment (Permit to Work).
- b. Ensure the valve is in the closed position; remove the valve operator (Item 32) by removing the operator nuts (Item 30).
- c. Remove the shaft key (Item 35), mounting plate (Item 17) and the mounting plate screws (Item 25).
- d. Remove the anti-blowout device (Item 37).
- e. Slowly loosen the gland nuts (Item 29) but do not fully remove. If leakage occurs whilst loosening the gland nuts allow the leakage to stop before fully removing the nuts. If the leakage continues check to ensure that the valve is not pressurised prior to continuing any further work.
- f. Remove the gland plate (Item 15) and gland spigot (Item 16). Note: on some Tritec models the gland plate and spigot may be combined into one item.
- g. Using a gland packing removal tool remove the gland packing (Item 33). Take care not to damage/score the shaft or valve body gland bore.
- h. Ensure all existing gland packing, fluid or debris is removed from the gland packing area. It is not recommended to use an airline to 'blow' any debris from the gland area as this may force it into the bearing cavity and damage the shaft and/or bearings.
- i. Examine the shaft and valve body gland bore for any damage or wear. If any damage or wear is evident contact Tomoe for advice.

6.3.2 Fitting New Gland Packing

- a. Prior to inserting the new packing set they should be checked for signs of damage. If any of the gland packing is damaged they should not be used and new gland packing should be obtained.
- b. Insert the new packing set (Item 33) being sure to the split in the packing is rotated 90° from the last packing ring. (see fig. 5a)
- c. After fitting each turn of gland packing, use the gland spigot (Item 15) to compress the packing.
- d. Fit the gland spigot (Item 15) and gland plate (Item 16) and tighten the gland nuts (Item 29) by hand ensuring the gland plate remains parallel to the valve body (see fig. 5b)
- e. Once the gland nuts are finger tight continue to tighten them using a calibrated torque wrench to the torque setting specified on the relevant GA drawing.
- f. Fit the anti-blowout device (Item 37). (see fig. 5c)
- g. Fit the mounting plate (Item 17), ensuring the dowel pins (Item 18) are fitted. Replace the mounting plate screws (Item 25) and tighten to the torque specified on the GA drawing.
- h. Fit the key (Item 35) into the shaft (Item 8) keyway.
- i. Fit the operator (Item 32). (Please refer to 5.3.3)



IMPORTANT

Ensure instructions in section 6.3 entitled 'Operator Re-fitting Instructions' are followed. Failure to follow these instructions can seriously damage the valve, and may result in the valve being returned to the factory for repair

IMPORTANT:
Do not be tempted to over tighten the gland nuts as this may increase the valve operating torque.

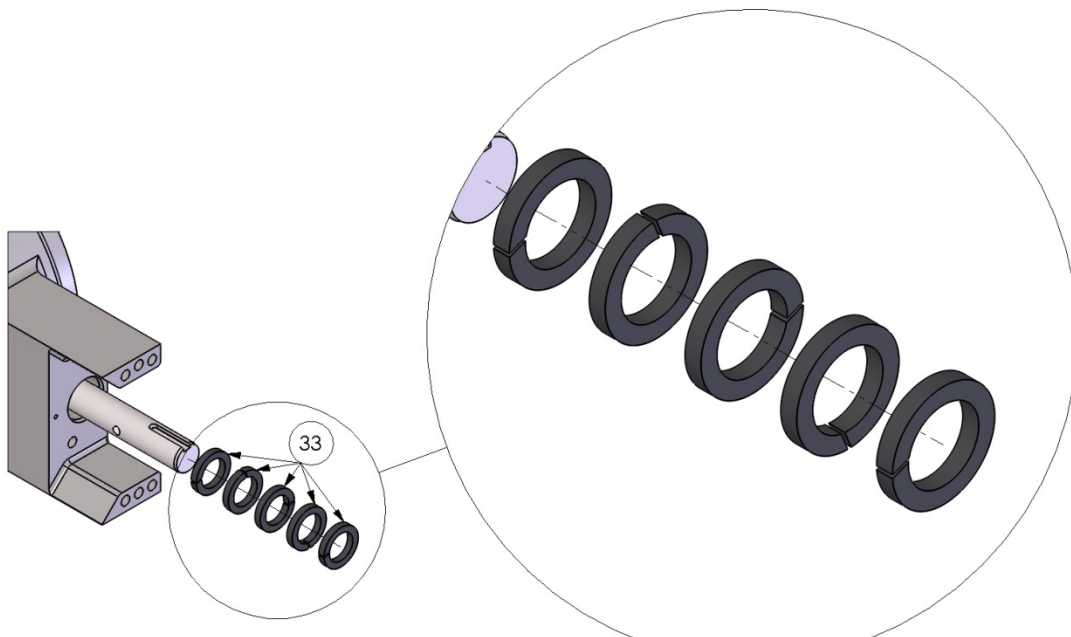

Fig. 5a

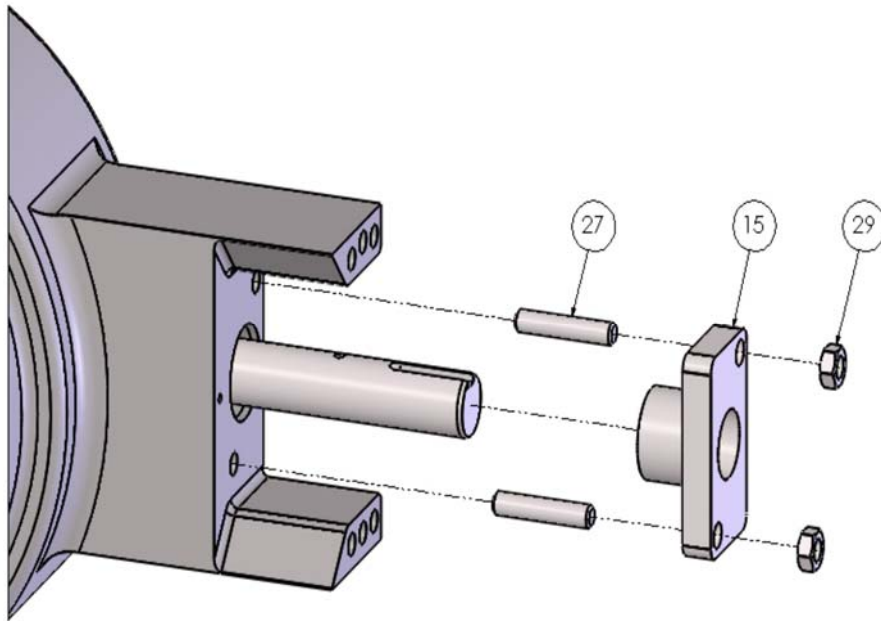

Fig. 5b

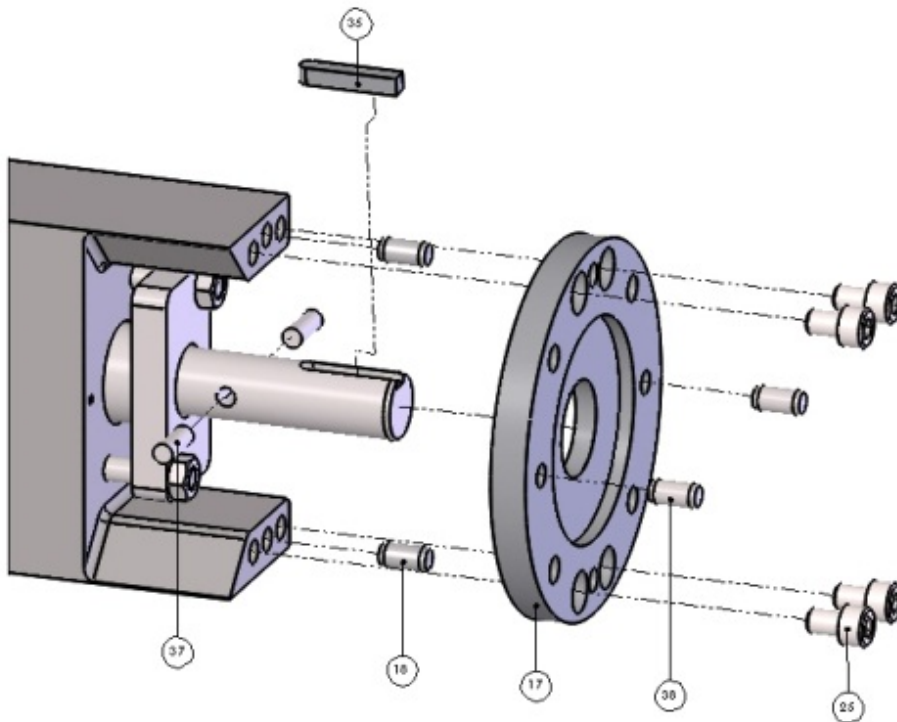

Fig. 5c

6.3.3 Operator Re-fitting Instructions (after replacement of Gland Packing)

- a. Ensure base of operator (Item 32), mating face of mounting plate (Item 17) and operator shaft bore is clean and free from dirt and swarf.
- b. Check number and size of holes on operator and mounting plate match each other.
- c. Ensure dowel pins (Item 18) are fitted to ensure the operator is centralised and does not distort the shaft.
- d. The valve disc (**except when fitting a fail open operator**) should be in the closed position.
- e. Prior to fitting the operator a spacer is to be fitted between the end cover (Item 13) and the end of the shaft. This prevents the internal components disc/disc seal being forced downwards and potentially damaging the body seat and disc seal – please consult with Tomoe Valve Ltd for details. (see fig. 6)

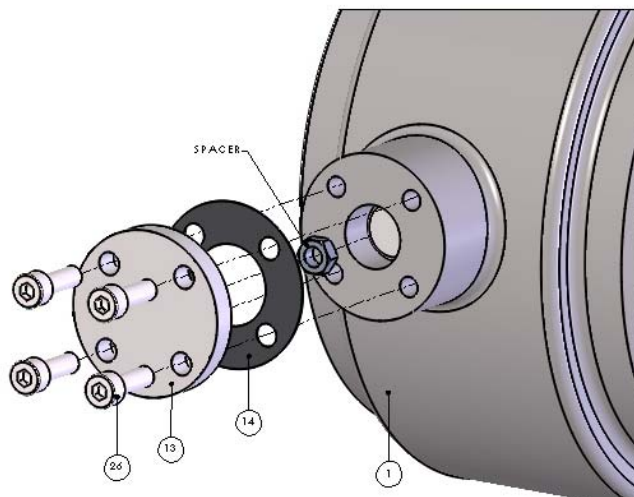

Fig. 6

- f. The operator must not be forced onto the shaft as this may damage the valve. Ensuring the shaft and operator shaft bore are clean and are free from burrs should be sufficient to allow the operator to be fitted relatively easily. The use of a suitable lubricant applied to the shaft is also acceptable.
- g. Once fitted the operator should be bolted in position with the operator studs (Item 28) and nuts (Item 30).
- h. **Once the operator is secured ensure the spacer is removed from between the end cover and shaft.** Fit the end cover (Item 13) and end cover gasket (Item 14) and tighten the end cover screws (Item 26) to the torque specified on the GA drawing following the opposite rule for bolt torque tightening.

6.4 Replacement of Body Seat and Disc Seal

The Tomoe Trittec valve features a field replaceable body seat (Item 3) and disc seal (Item 6). The seat and seal can be replaced without specialised tools, and without the need to return the valve to the factory. The components are precision machined and therefore can be replaced independently or as a pair. Due to the valve geometry the components must be fitted with the correct radial alignment. The body seat (Item 3) body seat retaining ring (Item 4), disc seal (Item 6), body (Item 1) and disc (Item 2) all have an alignment arrows in the same position. To aid alignment the components are marked to show the 12 o'clock position (see figs 8 & 8a).

6.4.1 Dis-assembly

- a. Set the disc (Item 2) approx. 10 - 15° from the fully closed position.
- b. Remove the body seat screws (Item 24).
- c. Remove the body seat retaining ring (Item 4), the body seat (Item 3) and the body seat gasket (Item 5).
- d. Set the disc to a level and closed position.
- e. Remove the disc seal screws (Item 22).
- f. Remove the disc seal (Item 6) and the disc seal gasket (Item 7).
- g. Examine the disc seal and body seat gasket sealing surfaces on the valve body for any signs of wear or damage. If any damage is evident contact Tomoe Valve for advice. Remove any existing gasket debris taking care not to scratch the gasket sealing surfaces.

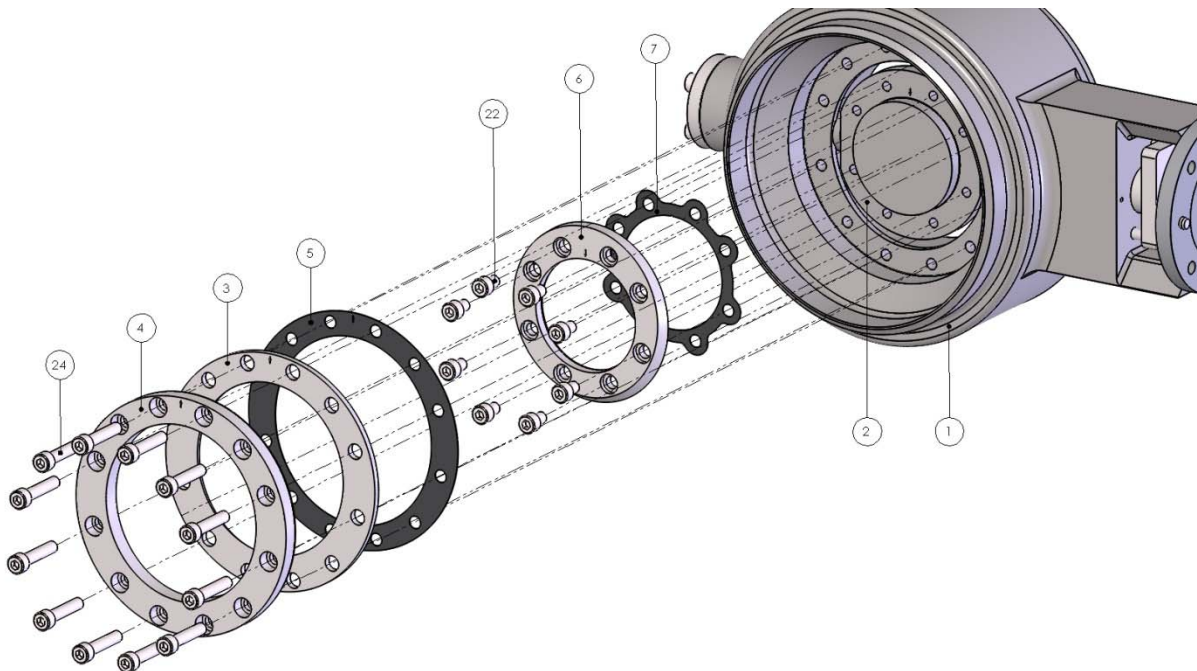

Fig. 7

6.4.2 Assembly

- a. Ensure the disc is in the correct position by pushing it as far as possible towards the operator by inserting a temporary spacer between the end cover and shaft. (Please refer to 5.3.3)
- b. The correct position can be verified by checking the thrust gap between the disc (Item 2) and the thrust ring (Item 11). The correct thrust gap dimension will be shown as 'Detail A' on the relevant valve GA drawing.
- c. Fit the disc seal gasket and disc seal ensuring the alignment mark on each component is in the correct position in relation to the valve body. (see fig. 8a)
- d. Fit the disc seal screws (Item 22) and tighten to the torque specified on the GA drawing using a calibrated torque wrench.
- e. Ensure the disc is in the closed position. Fit the body seat gasket (Item 5) and body seat (Item 3) ensuring the alignment mark on each component is in the correct position in relation to the valve body.
- f. With the valve positioned with the drive end of the shaft in the 3 o'clock position and the end cover in the 9 o'clock position open the disc approximately 10 degrees.
- g. Place one finger on the body seat in the 6 o'clock position as shown. (see figs. 8 & 9)

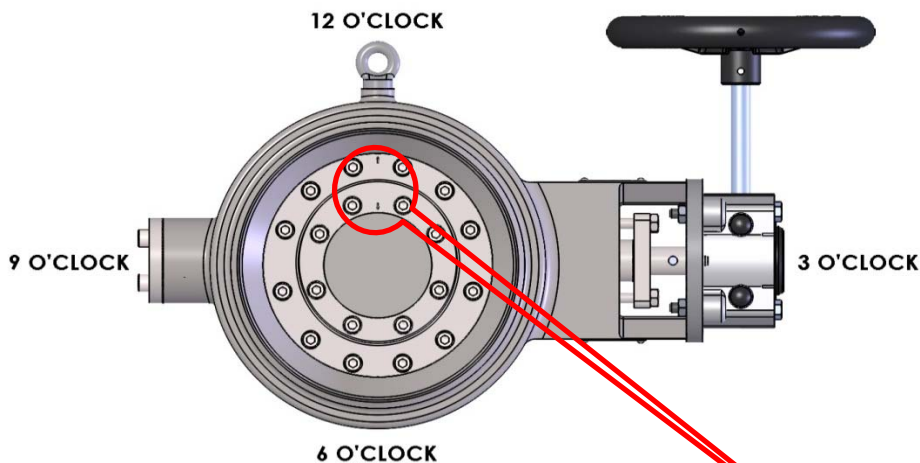

Fig. 8

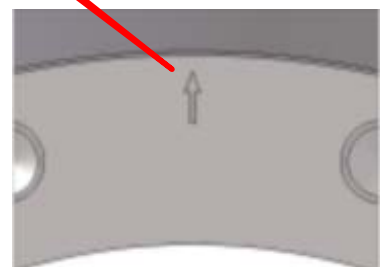

Fig. 8a

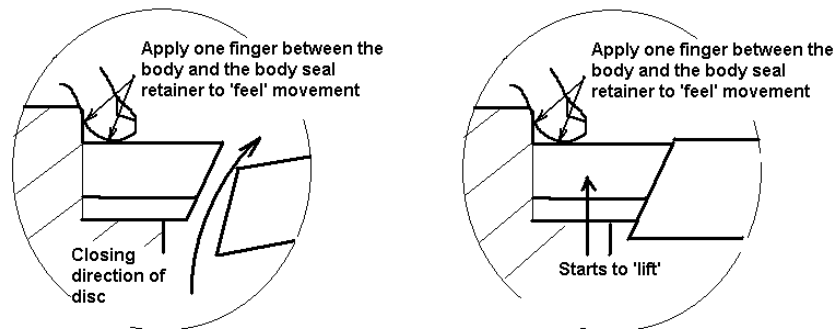

Fig. 9

- h. Slowly close the disc until you feel the body seat start to lift. To verify the correct fit the body seat should 'rock' when pressed in the 3 and 9 o'clock position. If no 'rock' is evident contact Tomoe Valve for advice. (see fig. 9)
- i. Fit the body seat retaining ring (Item 4) and the body seat screws (Item 24) and tighten by hand to secure in position.
- j. Tighten the body seat screws to the torque specified on the GA drawing using a calibrated torque wrench. Tighten the screws in 25% increments (i.e. specified torque ÷ 4) in the sequence shown. (see fig. 10)

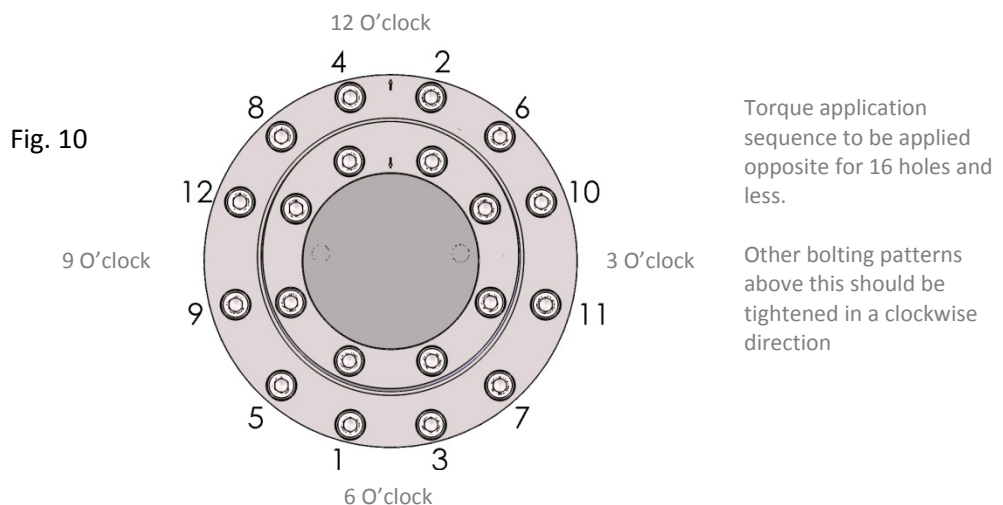

Fig. 10

- k. Continue to tighten in 25% increments until the final torque is achieved.
- l. Due to the nature of gasket relaxation the valve should be allowed to 'sit' for approximately two hours. The disc seal and body seat screw torques should then be checked to see if any slackening has occurred. If slackening of the screws has occurred then the screws should be tightened to the torque specified on the GA drawing in the sequence shown in Fig. 10.
- m. Remove the temporary spacer between the end cover and shaft and re-fit the end cover gasket and end cover.
- n. Tighten the end cover screws to the torques specified on the GA drawing.
- o. Note: For certain applications Tritec valves are supplied with tack welded disc seal screws (Item 22) and body seat screws (Item 24). Contact Tomoe Valve for advice on re-tack welding the screws.

6.5 Additional Procedure for Valves with PTFE/metal body seat

To aid sealing capabilities it may necessary to warm the body seat to enable it to form to the profile of the disc seal. This is due to the cold flow characteristics of PTFE.

6.5.1 Valves up to and including 6" NB

- a. Assemble the new components as detailed in the procedure above.
- b. Set the valve to the fully closed position.
- c. Using boiling water, pour enough water into the front bore of the valve to cover the body seat retaining ring (Item 4). This will soften the PTFE laminate and allow the material to flow.
- d. Allow approximately 2-3 minutes for the heat to take effect and then re-tighten the body seat screws (Item 24) and disc seal screws (Item 22) to the torques specified on the GA drawing.
- e. Allow the valve body seat to cool before opening the valve.

6.5.2 Valves 8" NB and larger

- a. Due to the amount of heat required to soften the PTFE a more direct method of heating is required.
- b. Assemble the new components as detailed in the procedure above.
- c. Set the valve to the fully closed position.
- d. Using a naked flame (e.g. gas torch) apply heat to the disc seal and body seat retaining ring area.
- e. Ensure the heat is applied evenly and not concentrated in one position for any length of time.
- f. Stop applying heat as soon as the body seat retaining ring is too hot to touch.
- g. Re-tighten the body seat (Item 24) and disc seal screws (Item 25) to the torques specified on the GA drawing.
- h. Allow the valve to cool (cold to touch) before opening the valve.

Section 7 - PRODUCT WARRANTY

1. Warranty Coverage

“Goods” means the items stated on the Buyers purchase order and Tomoe Valve Ltd (UK) sales acknowledgement with a serial number set out on the supplied product test certificate and certificate of conformity as supplied with the Goods.

“Tomoe Valve Ltd (UK)” means Tomoe Valve Ltd based in the United Kingdom as per the registration number and address stated above.

“Buyer” means the purchaser of the Goods in placing a purchase order on Tomoe Valve Ltd (UK).

“End User” means the user of the Goods if the user is not the Buyer

The warranty guarantees the Goods against material defect or mechanical failure for the warranty period stated below and is subject to the exclusions detailed under section 4 warranty exclusions.

If the Goods do not comply with the warranties set out above Tomoe Valve Ltd (UK) shall at its cost and expense and discretion either:

- Repair or replace the defective Goods
- Or give a full credit or refund for the price paid by the Buyer for the defective Goods.

This warranty and any claims or disputes arising in connection with it, is governed by English & Welsh law and the parties submit to the exclusive jurisdiction of the English and Welsh courts.

2. Warranty Period

- 18 months from date of shipment or 12 months from installation (whichever occurs first).
- All out-of-warranty products returned for repair or refurbishment, the repaired or refurbished Goods shall be warranted to be free from material defects and mechanical failure for ninety (90) days from the shipment of the Goods by Tomoe Valve Ltd (UK).

3. Warranty Claims

In the event of a suspected defect the Buyer / End User must:

- Give written notice of any defect to Tomoe Valve Ltd (UK) within 30 days of the time when the Buyer / End User discover or ought to have discovered the defect.
- The Buyer / End User must give Tomoe Valve Ltd (UK) a reasonable opportunity, after receiving the notice, to examine any defective products.
- Where possible, and to make investigation of the claim as quick and simple as possible the notification should include:
 - the valve serial number (located on the valve nameplate)
 - a description of the problem/defect
 - process conditions (temperature, pressure, line media)
 - geographical location of the valve
 - contact details of the relevant Buyer / End User representatives

The decision of Tomoe Valve Ltd (UK) on all matters governed by this warranty and in particular, but not limited to, the nature and cause of any defect or failure shall be conclusive and binding on the Buyer/End User.

Repairing or replacing the defective Goods does not change the warranty coverage or extend the warranty period.

Note: An End User of the Goods (if the End User is not the Buyer) can make a warranty claim subject to the conditions of this warranty but Tomoe Valve Ltd (UK) reserves the right to have written authorisation from the Buyer prior to commencing any repairs.

4. Warranty Exclusions

This warranty does not cover the following:

- a) Issues resulting from failure to comply with installation instructions, product drawings, maintenance instructions or improper installation.
- b) Issues resulting in whole or in part from alteration or modification of the Goods(s) by any party other than Tomoe Valve (UK) or its authorised representative.
- c) Defects not reported to Tomoe Valve Ltd (UK) within the applicable warranty period.
- d) Defects resulting from misuse, negligence or accident by any party other than Tomoe Valve Ltd (UK) or its authorised representative.
- e) Tomoe Valve Ltd (UK) is not liable for the quality, performance or fitness for purpose of any hardware (including but not limited to said equipment's software and operating systems) manufactured by a third party. Such items may be warranted by the original equipment manufacturer (e.g. gearbox or actuator).
- f) If any defect is attributable to further use of the product after the Buyer discovers or ought to have discovered the defect.
- g) If any defect is attributable to fair wear and tear, abuse, improper use in an environment or for a purpose for which the product was not designed or intended.
- h) If the Buyer alters or repairs the product without the written consent of Tomoe Valve Ltd.
- i) This warranty can be availed by the first Buyer only and is not transferable from one user to another.

5. Warranty Limitations

TOMOE VALVE LTD (UK) IS NOT LIABLE FOR ANY INDIRECT OR CONSEQUENTIAL LOSS OR DAMAGE (INCLUDING BUT NOT LIMITED TO LOSS OF DATA, PROFITS, BUSINESS, GOODWILL OR OTHERWISE) OR ANY CLAIMS OF THIRD PARTIES OTHER THAN REPAIR, REFURBISHMENT OR REPLACEMENT OF THE GOODS.



TOMOE valves can be found in operation in a vast range of industries worldwide, both onshore and offshore, providing unsurpassed levels of leak tightness and wear resistance and making a valuable contribution to overall process efficiency.

- Water Treatment

- Chemical Processing

- Food & Drink

- Sugar Processing

- Oil & Gas

- Offshore

- Petrochemical

- HVAC

- Power Generation

- LNG

- Iron & Steel

- Marine

- Cement

- Powder Handling

Installation and Maintenance Manual
Document No: TT/QA/017

TOMOE
www.tomoeurope.co.uk