

TRITEC

150 / 300 / 600 /
900 / 1500 /
2500lb Range

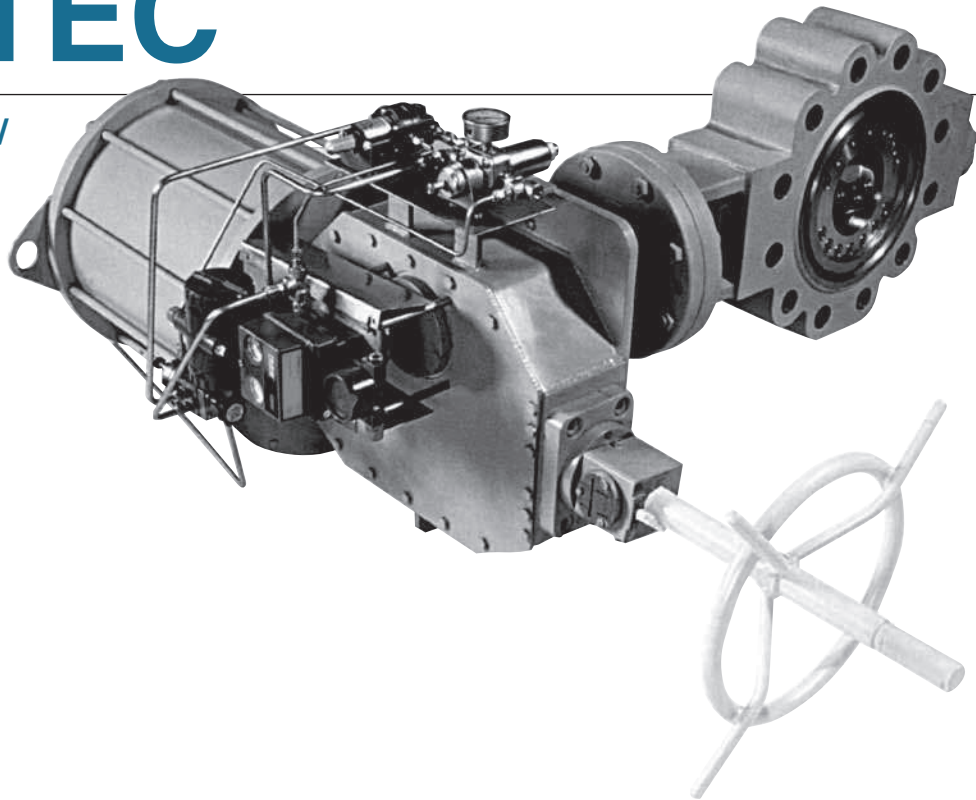

Features and Benefits

- Triple offset and ellipsoidal sealing Geometry
- Bi-directional bubble tight shut-off
- Inherently Firesafe
- Developed Geometry results in
 - Zero Seat/Seal Friction
 - Low Torques
 - Extended Service Life
 - Continued Seal through Thermal Cycling
 - Torque Seating
- Excellent flow and throttling characteristics covering services from Cryogenic to high temperature
- Excellent control of Fugitive Emission by virtue of Rotary stem movement and advanced packing materials
 - Less than 50ppm on Fugitive Emission Test to cover EPA21
 - Other tests available on request
- Firesafe meet API Std 607 4th / 5th Edition and BS 6755 part 2 / API 6FA
- Available Fully Rated to Class 2500Lb
- Fully rated for end of line duty
- Standard materials conform to NACE, all exotic materials also available
- Laminated seat is mounted in the body, removing it from the erosive effects of the flowing media
- Seat is self centering “floating” design
- Both Seat and Seal are field replaceable without special tools
- Unique elliptical bolting pattern allows foolproof replacement of seat and seal
- Gasket Sealing Face is completely uninterrupted by fixings
- Suitable for use with Spiral Wound gaskets and all flange finishes including RTJ
- Antiblowout device on shaft with both internal and external retaining systems according to API Std 609
- ISO mounting flange allows easy fitting and changing of operators
- Operator is bolted and doweled to prevent radial movement and subsequent loss of seating torque
- Body counterbore and seat bolting arranged elliptically to ensure equal support, gasket land and gasket loading all around the elliptical edge of the laminated body seat
- Inboard and outboard thrust mechanisms prevent decentralising of disc, even under high temperature and line pressure
- By eliminating seat-seal friction on unseating, Tritec removes the “Blind Zone” and increases the rangeability or controllable range to the full 90° of movement. The rotation geometry and inboard bearing design reduce the effect of dynamic torque and mechanical noise-vibration, increasing midrange control accuracy. Cavitation and Noise reducers are available to complement the Tritec valve under high pressure drop process situations

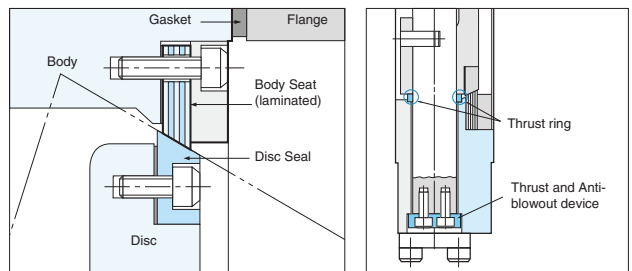

Offset Valve-Disc / Seat Friction

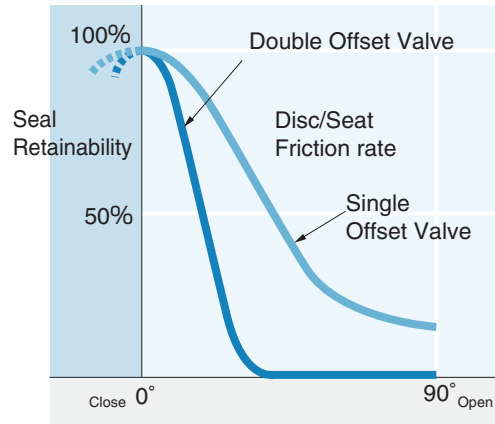
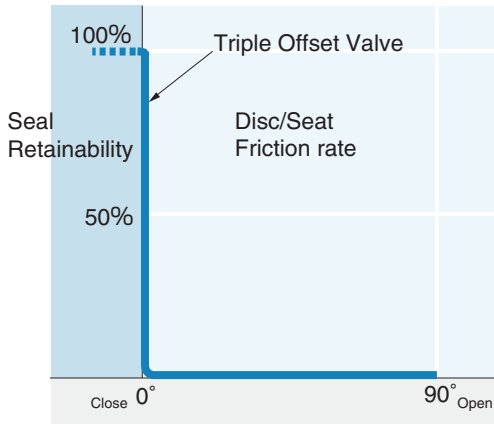

Tracing the evolution of Triple Offset design

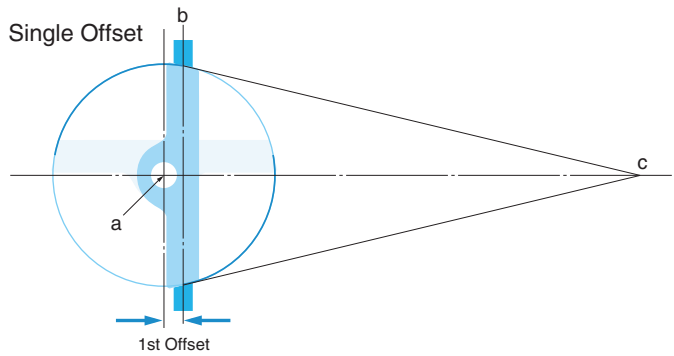

The centre of rotation is moved back from the centreline of the valve disc. The seat and seal are designed conically and on centre. This design relies on a frictional interference seal and so is applicable only to soft seated valves.

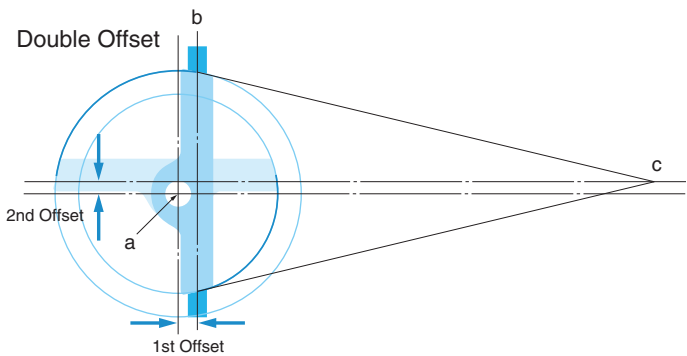

The centre of rotation is moved from the centerline of the valve body. The seat and seal design remains conical and on centre. This design again relies on a frictional interference seal, but the length of rotation over which this friction occurs is reduced, allowing a larger range of process resistant seat materials to be used. However, these materials must be relatively soft or highly elastic to prevent "jamming".

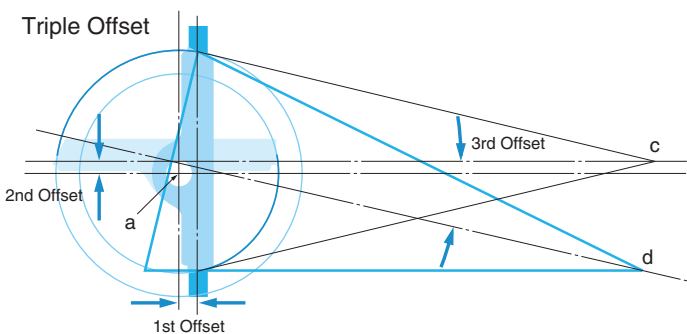

The centreline of the cone is rotated away from the valve centreline resulting in an ellipsoidal profile and providing the third offset. With this geometry, seat seal interference is completely eliminated ensuring long sealing life. The result is a torque seated, process-pressure-aided FRICTIONLESS seal. The geometry allows the body seat to be used as the closed limit stop, aiding operator adjustment. The Triple Offset design is ideally suited to metal seated valves providing bubble-tight performance in high temperature, high pressure and firesafe applications.

Butterfly Valve

TRITEC

TT2

334A

302A/303Q

304A/304Q

302Y/304Y

304M (HLV)

507V/508V

DTM

846T/847T/847Q

841T/842T

700Z

700G/704G/705G

700GB

731P/732P/731Q/732Q

71LG

700E/700K/700S

704G/722F/720F

KRV

227P

907H/908H (MKT)

903C

Standard Specifications

Design	API Std 609, BS 5155, ANSI B16.34, ASME SEC VIII	
Valve Sizes ^{※1}	2"(50mm) — 66"(1650mm)	
Pressure Classes	Class 150, 300, 600, 900, 1500, 2500	
Body Styles	Lugged, Wafer Flangeless, Double Flanged, Butt Weld End	
Flange Accommodation ^{※2}	ANSI B16.5:DN50 — DN600 ANSI B16.47 Series A&B : DN700 — DN1650	
Face to Face ^{※3} Dimensions	LUG and WAFER Type API Std 609 Table 2 : DN 80 — DN600 API Std 609 Table 1 : DN750, 900, 1050, 1200 ISO 5752 Wafer Short : DN700, 800, 1000 DOUBLE FLANGED Type ISO 5752 / BS 5155 Double Flange Short	
Pressure— Temperature Ratings	ASME/ANSI B16.34 : for Steel ASME/ANSI B16.24 : for Bronze Working Temperature Range as Standard −29°C (−20°F) to +538°C (1000°F) With selection of suitable materials −46°C (−51°F) to +700°C (1292°F)	
Pressure Tests	Shell Test, Seat Test : API Std 598 Seat Leakage Rate API Std 598, ISO 5208 Rate A, ANSI B16.104 (ANSI / FCI 70-2) Class VI Certified Firesafe to API 6FA and API 607	
Firesafe	Certified Firesafe to API 6FA and API 607	
Marking	API Std 609 MSS SP-25	
Operators	Manual Gear, Electric, Pneumatic, Hydraulic	
Standard materials	Body	A216 WCB, BS EN 10025 (Carbon Steel), A351 CF8M
	Disc	A216 WCB, A351 CF8M
	Stem ^{※4}	A564 type 630 H1150+1150
	Body seat	316SS / Graphite
	Disc seal ^{※5}	316SS

※1. Please contact the sales office for larger sizes.

※2. JIS 10K, 20K, 30K MSS, API, BS, DIN, PN, ISO also available on request.

※3. ISO 5752 Gate Valve Short (Basic series 3) on request.

※4. Use Inconel 718 for over 400 degrees C.

※5. Titanium nitride hardened, Stellite #6 welding is available as an option.

Design Options

DOUBLE BLOCK & BLEED VALVES.

To allow verifiable, maintainable shut-off in critical isolation applications. Fire tested to AP16FA & AP1607.

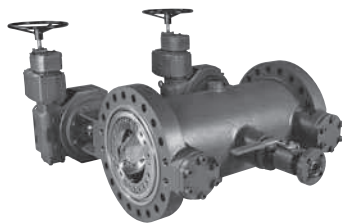

BUTT WELD WITH TOP ENTRY.

Allowing complete maintainability on valves which are welded into line.



Design Options

CONTROL VALVES.

Frictionless seating means increased rangeability, allowing the Tritec valve to perform in both control and isolation application.

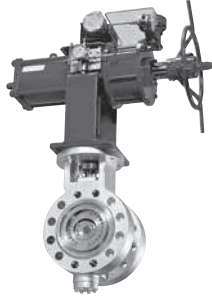

FIRE SAFE DESIGN.

Fire safe approval to API 6FA and API 607.



STEAM JACKETED VALVES.

To maintain process temperature ensuring media remains liquid. Disc and shaft steam tracing as an option.



Full-Jacket type



Semi-Jacket type

VALVES TO REDUCE FUGITIVE EMISSION.

Designed to reduce fugitive emission, testing is available to all international standards plus customer specific requirements.



GATE VALVE FACE TO FACE.

For the direct replacement of gate valves, all dimensions are exactly as per the standard Double Flanged valve with the exception of the face to face dimension which is shown below. (in accordance with ISO 5752 gate valve short).

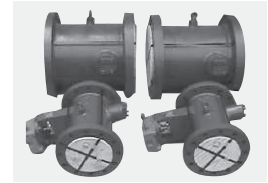

(Unit: mm)

Valve Size		150Lb	300Lb	600Lb	900Lb	1500Lb
mm	inch	Flanged Gate F-F	Flanged Gate F-F	Flanged Gate F-F	Flanged Gate F-F	Flanged Gate F-F
50	2	178	216	—	—	—
80	3	203	282	356	—	—
100	4	229	305	432	457	—
150	6	267	403	559	610	705
200	8	292	419	660	838	832
250	10	330	457	787	838	991
300	12	356	502	838	965	1130
350	14	381	762	889	1029	1257
400	16	406	838	991	1130	1384
450	18	432	914	1092	1219	1537
500	20	457	991	1194	1321	1664
600	24	508	1143	1397	1549	1943

Allows direct replacement of existing gate valves without modification of pipework.

Disc remains within the body face to face in the fully open position to allow removal of the valve from pipework even when the valve is open.

Reduction of fugitive emission due to quarter turn rather than linear shaft movement.

Reduced operator costs due to quarter turn rather than multi turn / linear.

Referential Drawing

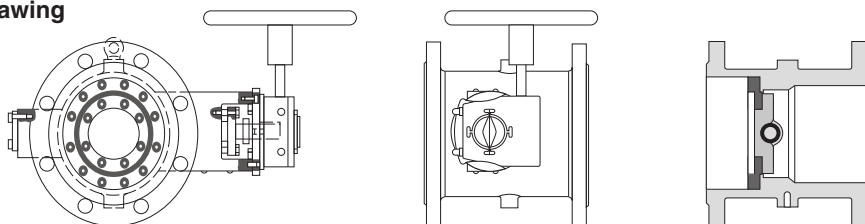

Butterfly Valve
TRITEC
TT2
334A
302A/303Q
304A/304Q
302Y/304Y
304M (HLV)
507V/508V
DTM
846T/847T/847Q
841T/842T
700Z
700G/704G/705G
700GB
731P/732P/731Q/732Q
71LG
700E/700K/700S
704G/722F/720F
KRV
227P
907H/908H (MKT)
903C

Pressure-Temperature Ratings

Body	A216	Gr. WCB
Disc	A216	Gr. WCB
Shaft	A564	Type 630

Body	A351	Gr. CF8M
Disc	A351	Gr. CF8M
Shaft	A564	Type 630

Temperature		Working Pressure (MPa)					
(°F)	(°C)	150	300	600	900	1500	2500
-20	-29	1.96	5.11	10.2	15.3	25.5	42.6
100	38	1.96	5.11	10.2	15.3	25.5	42.6
122	50	1.92	5.01	10.0	15.0	25.1	41.8
212	100	1.77	4.66	9.32	14.0	23.3	38.8
302	150	1.58	4.51	9.02	13.5	22.5	37.6
392	200	1.38	4.38	8.76	13.1	21.9	36.5
482	250	1.21	4.19	8.39	12.6	21.0	35.0
572	300	1.02	3.98	7.96	12.0	19.9	33.2
617	325	0.930	3.87	7.74	11.6	19.4	32.3
662	350	0.840	3.76	7.51	11.3	18.8	31.3
707	375	0.740	3.64	7.27	10.9	18.2	30.3
752	400	0.650	3.47	6.94	10.4	17.4	28.9
797	425	0.550	2.88	5.75	8.63	14.4	24.0
842	450	0.460 ^{*1}	2.30 ^{*1}	4.60	6.90	11.5	19.2
887	475	0.370 ^{*1}	1.74 ^{*1}	3.49	5.23	8.72	14.5
932	500	0.280 ^{*1}	1.18 ^{*1}	2.35	3.53	5.88	9.79
1000	538	0.140 ^{*1}	0.590 ^{*1}	1.18	1.77	2.95	4.92

Temperature		Working Pressure (MPa)					
(°F)	(°C)	150	300	600	900	1500	2500
-20	-29	1.90	4.96	9.93	14.9	24.8	41.4
100	38	1.90	4.96	9.93	14.9	24.8	41.4
122	50	1.84	4.81	9.62	14.4	24.1	40.1
212	100	1.62	4.22	8.44	12.7	21.1	35.2
302	150	1.48	3.85	7.70	11.6	19.3	32.1
392	200	1.37	3.57	7.13	10.7	17.8	29.7
482	250	1.21	3.34	6.68	10.0	16.7	27.8
572	300	1.02	3.16	6.32	9.49	15.8	26.4
617	325	0.930	3.09	6.18	9.27	15.4	25.7
662	350	0.840	3.03	6.07	9.10	15.2	25.3
707	375	0.740	2.99	5.98	8.96	14.9	24.9
752	400	0.650	2.94	5.89	8.83	14.7	24.5
797	425	0.550	2.91	5.83	8.74	14.6	24.3
842	450	0.460	2.88	5.77	8.65	14.4	24.0
887	475	0.370	2.87	5.73	8.60	14.3	23.9
932	500	0.280	2.82	5.65	8.47	14.1	23.5
1000	538	0.140	2.52	5.00	7.52	12.6	20.9

(Notes) *1. Permissible, but not recommended for prolonged use above 800°F(427 degree C).
Please contact a sales office for temperatures outside of standard temperature range as detailed in the above table.

Pressure-Temperature Ratings (ANSI B 16.34-2004)

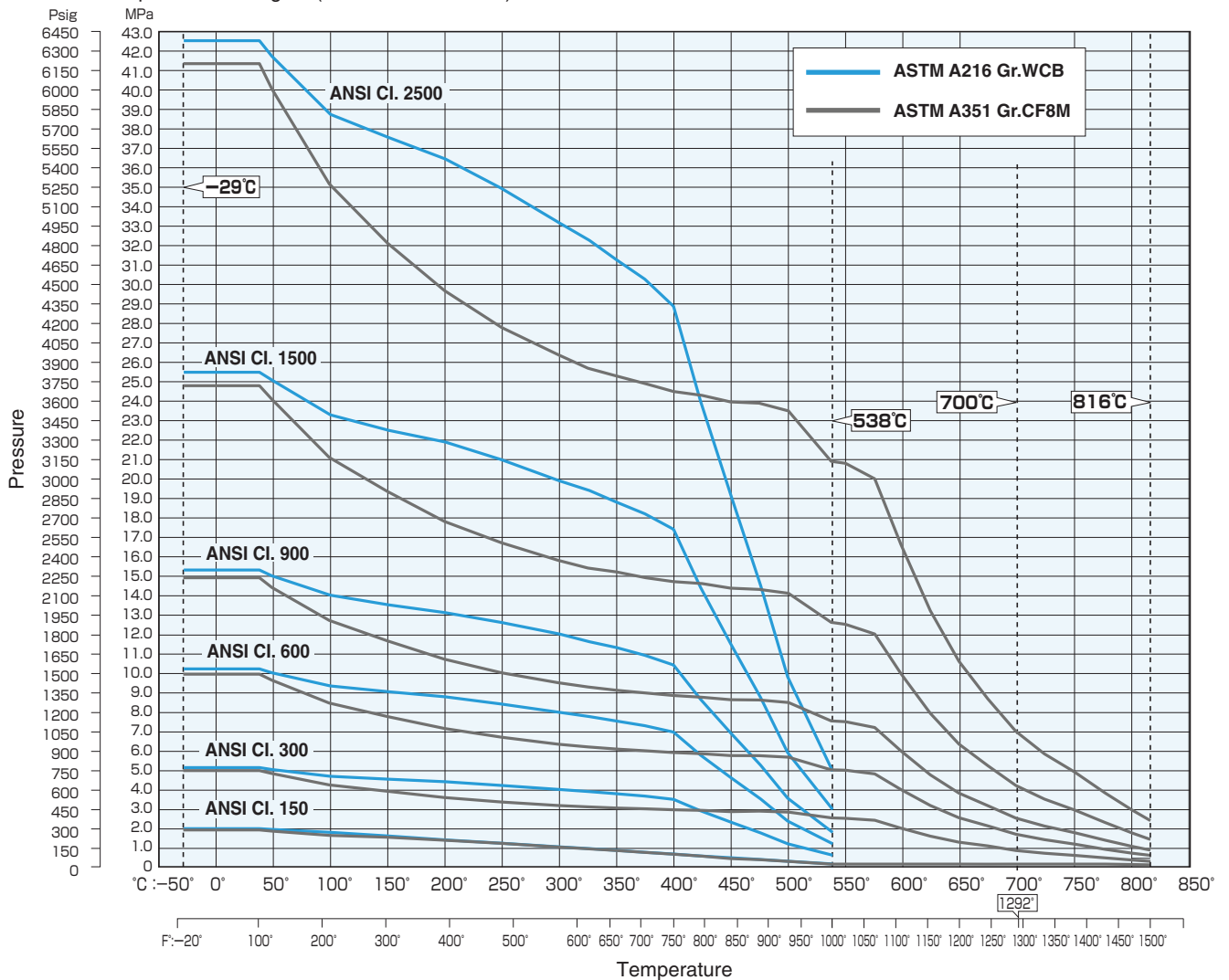

Allowable Seat Leakage Rates by Standard

Gas Test

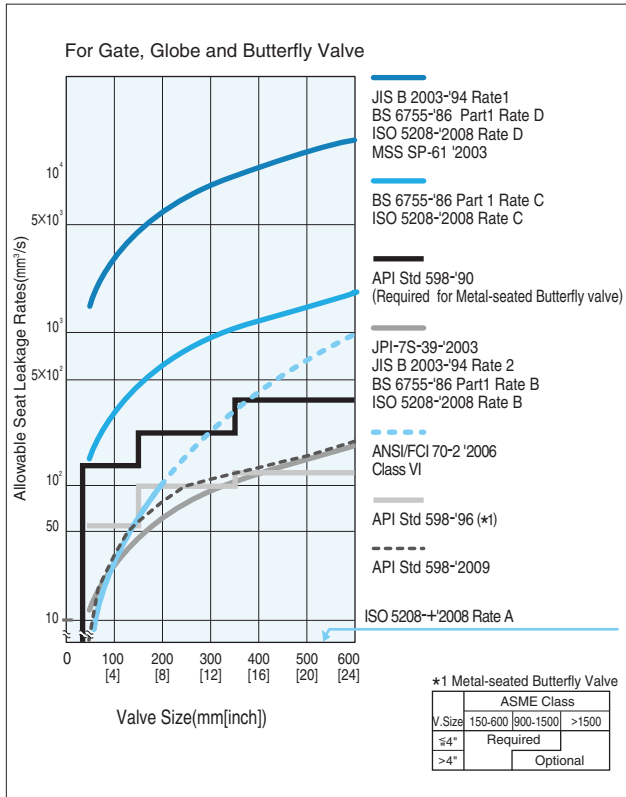

Hydrostatic Test

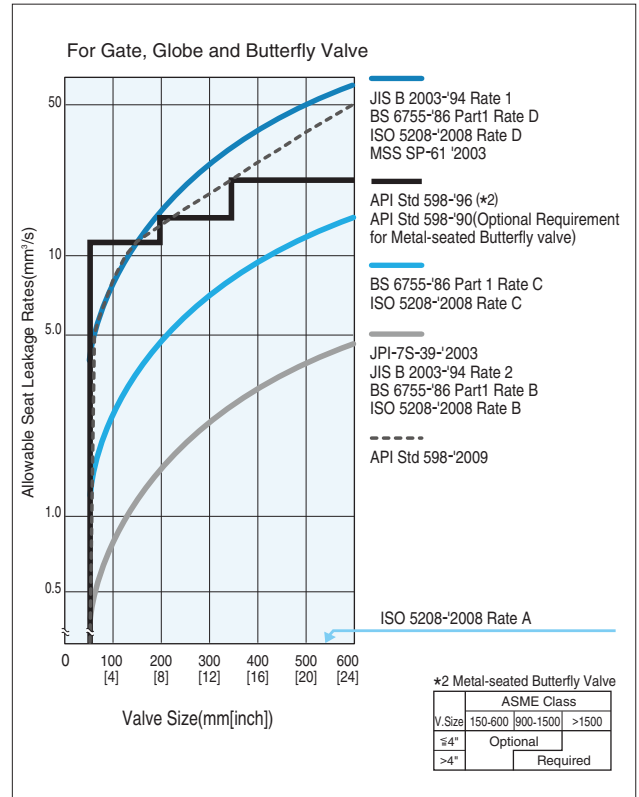

Allowable Seat Leakage Rates by Standard

Gas Test

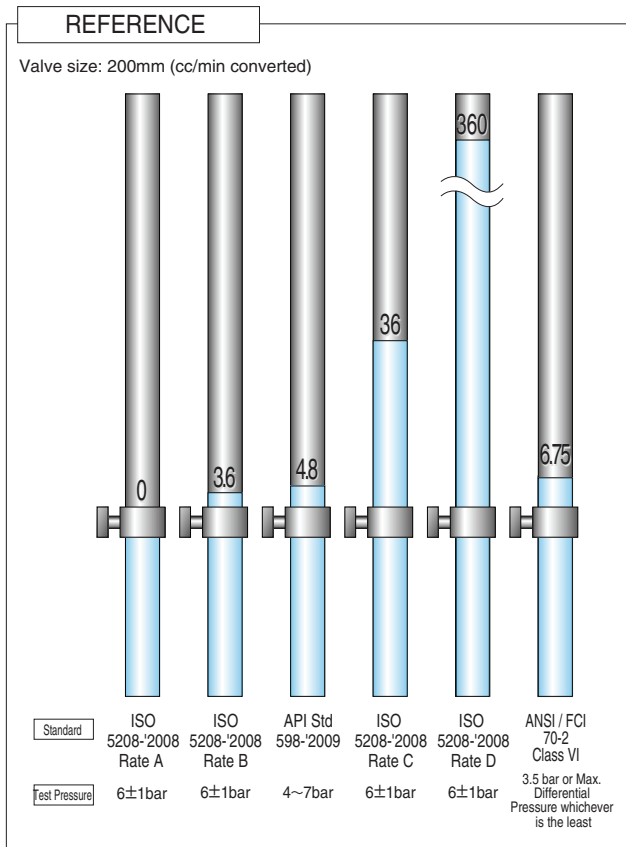

Hydrostatic Test

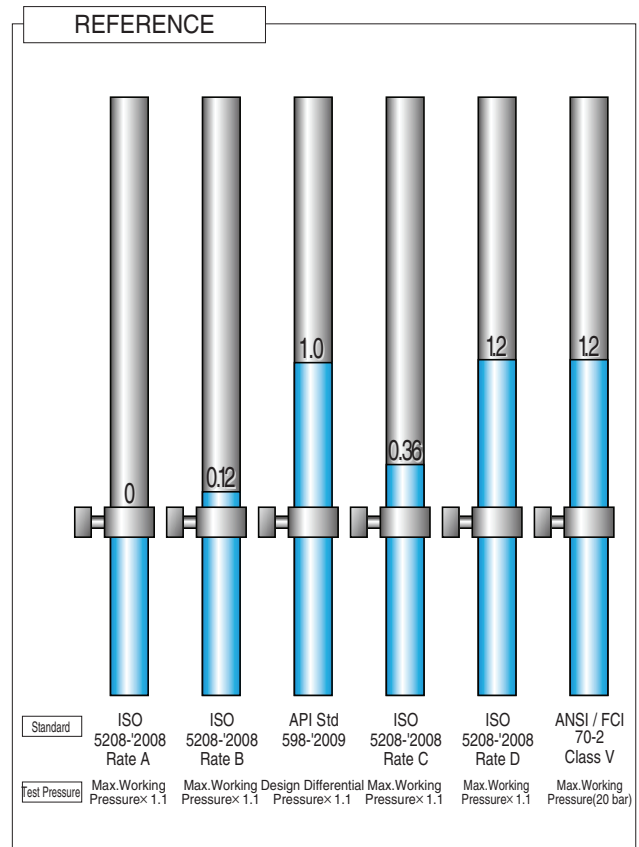

Butterfly Valve
TRITEC
TT2
334A
302A/303Q
304A/304Q
302Y/304Y
304M (HLV)
507V/508V
DTM
846T/847T/847Q
841T/842T
700Z
700G/704G/705G
700GB
731P/732P/731Q/732Q
71LG
700E/700K/700S
704G/722F/720F
KRV
227P
907H/908H (MKT)
903C

Operating and Maintenance Instructions

No	Description	Q'ty
1	Body	1
2	Disc	1
★	3 Body Seat	1
4	Body Seat Retaining Ring	1
★	5 Body Seat Gasket	1
6	Disc Seal	1
7	Disc Seal Gasket	1
8	Shaft	1
9	Shaft pin	2-4
10	Bearing	4
11	Thrust Ring	1-2
○	12 Thrust Pad	1
13	End Cover	1
14	End Cover Gasket	1
15	Gland Plate	1
16	Gland Plate Spigot	1

No	Description	Q'ty
17	Mounting Plate	1
18	Dowel Pin	2-4
19	Nameplate	1-2
22	Disc Seal Screw	1set
23	Thrust Pad Screw	2-3
24	Body Seat Screw	1set
25	Mounting Plate Screw	4-6
26	End Cover Screw	4~
27	Gland Stud	2
29	Gland Nut	2
★	33 Gland Packing	3
★	34 Gland Packing	2
35	Key	1
38	Anti-bowout Device	1-2

★ : Recommended Spare Parts

○ : Please refer to specific drawings

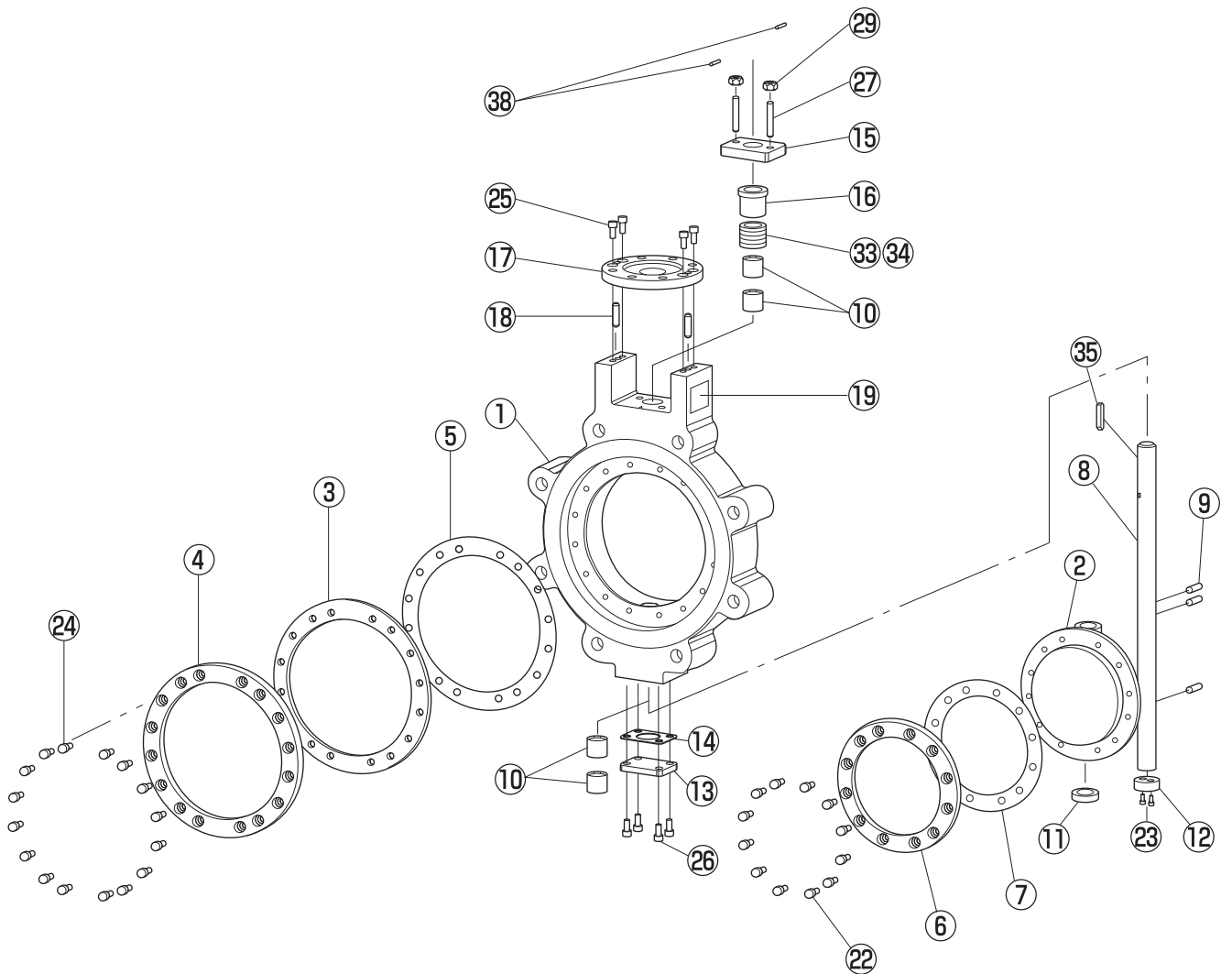

Operating and Maintenance Instructions

INTRODUCTION

This instruction provides general information on the operation, installation and maintenance of the Tritec triple offset valve. The Tritec valves have been designed and manufactured to operate in an aggressive environment under extremes of temperature and pressure for long periods and with minimal maintenance.

INSTRUCTIONS

PACKING

- All valves will be despatched with protective covers attached to the flange faces to protect the gasket sealing surfaces and internal trim.
- The valve disc is cracked off the seat in the almost closed position.
- The Tritec nameplate shown in the picture contains information such as size, pressure class, materials and the unique serial number.

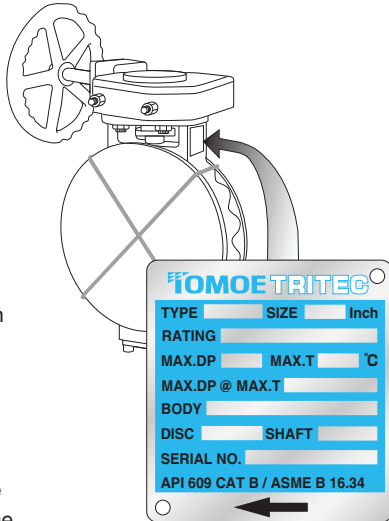

SPARE PARTS

- When ordering spare parts or discussing matters concerning this valve with the sales office, it is essential to quote the unique Serial Number of the valve which is to be found on the stainless steel nameplate attached to the valve body adjacent to the operator.

TRANSPORTATION

- Use crates or packing cases for ocean transportation.
- For overland transportation, a covered vehicle is recommended with protective sheets covering the valves.

STORAGE

- Store the valves indoors in a cool temperature between -10° and $+60^{\circ}\text{C}$, humidity at 70% or less.
- Do not remove the protective covers until ready to install valves.
- Machined ferrous surfaces are protected with an approved rust preventative. For long periods of storage, apply the rust preventative once a year to the unpainted surfaces.
- When storing valves unpacked, take care in protecting valves and actuators from excessive loads. Do not stack unpacked valves.
- If the valve is for clean gas duty and is being supplied "DEGREASED", a label is attached stating this and the valve sealed in a polythene covering. It is suggested that the valve is kept packed until it is to be installed in the pipeline.

UNPACKING

- Unpack valves just before installation.

INSTALLATION

- The valve is designed to seal against bidirectional flow and can therefore be installed with flow in either direction. However enhanced sealing life will be obtained with upstream flow against the shaft side of the disc. This preferred flow direction is shown on the nameplate attached to the valve body adjacent to the operator and also on the GA drawing. The valve may be installed in the pipeline with the valve shaft in a horizontal, vertical or intermediate position.
- Prior to installation, the pipeline must be cleaned from dirt and welding residues to avoid damage to the valve during operation.
- Ensure that the valve is closed prior to installation to avoid the risk of damage to the sealing surfaces.
- The valve must be lifted by the eyebolt or lifting eyes provided with the valve.
- The valve must not be lifted by the operator or handwheel.
- The valve must not be used for pipework alignment.
- The Lugged or Double flanged type valve is suitable for dead end service ie. end of line duty, in either direction (in case of the valve specified both directions) to the full rating pressure of the piping system.

Butterfly Valve

TRITEC

TT2

334A

302A/303Q

304A/304Q

302Y/304Y

304M (HLV)

507V/508V

DTM

846T/847T/847Q

841T/842T

700Z

700G/704G/705G

700GB

731P/732P/731Q/732Q

71LG

700E/700K/700S

704G/722F/720F

KRV

227P

907H/908H (MKT)

903C

TT2

Valve nominal size

80 to 600mm

Max. working pressure MPa

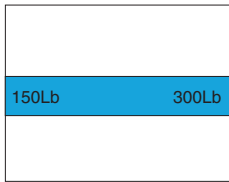

Working temperature range °C

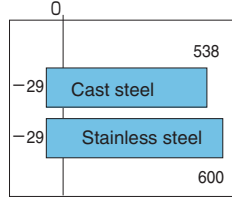

FS Fire safe certification to API607 5th Edition

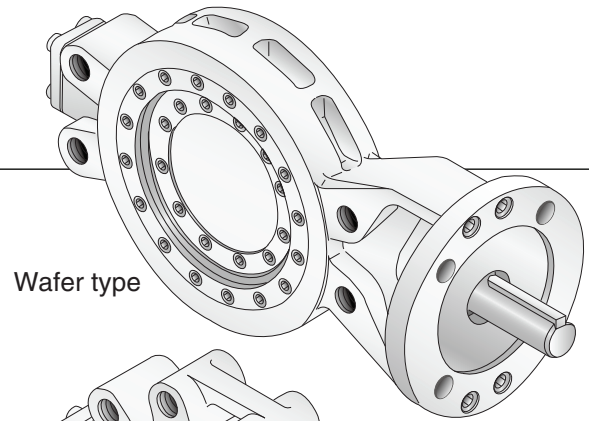
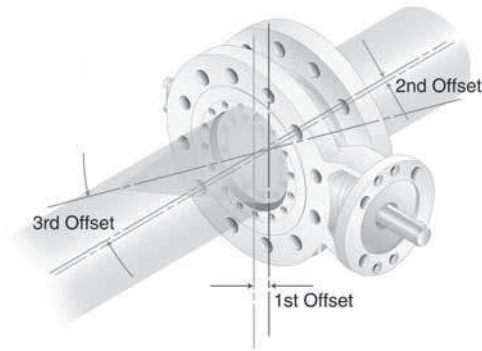

Wafer type

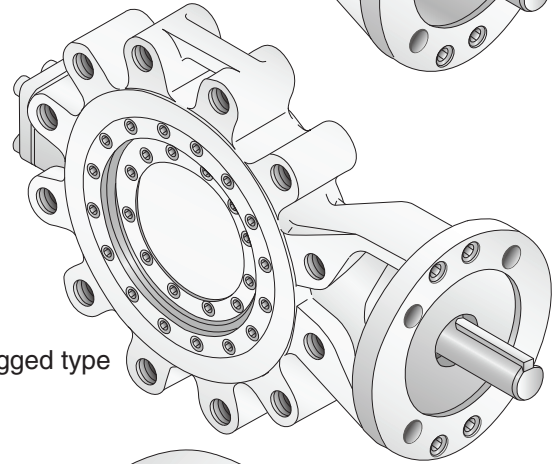

Lugged type

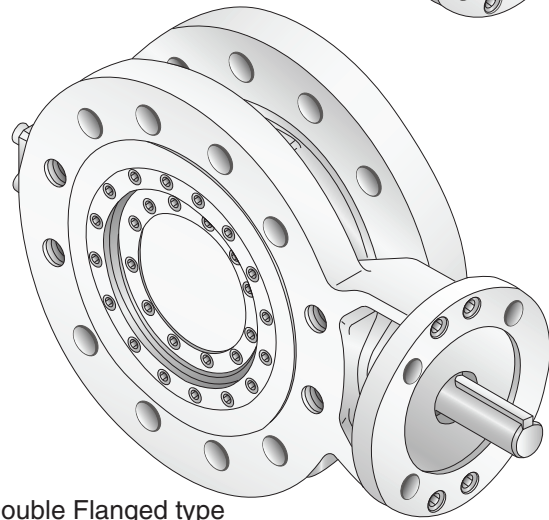

Double Flanged type

Always at the leading edge

Through an extensive commitment to Research & Development, TOMOE has remained at the leading edge of valve design for more than 50 years. The TT2 Triple Offset process valve is the result of advanced technology design and stringent testing to develop a valve that meets the high performance demands of applications where long life and positive shut-off under arduous conditions is essential.

The TT2 inherits the torque sealing, friction-free sealing design of other valves in the TT series and the unique triple offset and ellipsoidal sealing geometry guarantees zero leakage and bubble-tight shut-off.

In addition, the compact, lightweight design of the TT2 triple offset valve has revolutionised design and maintenance of piping systems in the OPC industry.

Smaller and lighter than traditional ball, globe and gate valves, the TT2 features a fully field-replaceable seat and seal design for increased plant efficiency and reduced cost of ownership.

Available in Wafer, Lugged and Double Flanged type body styles to 150 lb and 300 lb pressure ratings, the TT2 triple offset valve has fire safe certification to API607 5th Edition, making it inherently safe in high risk industry applications.

Features and Benefits

- Zero leakage with metal seat
- Compact, lightweight design
- Fully field replaceable seat and seal design
- Longer life cycle
- Fire Safe Certification to API607 5th Edition

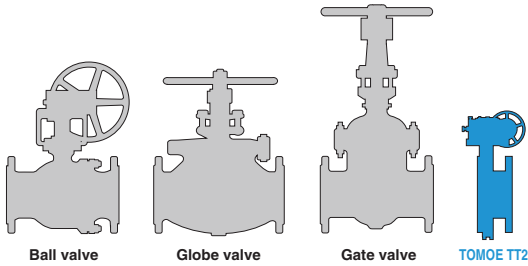

Pressure-Temperature Ratings

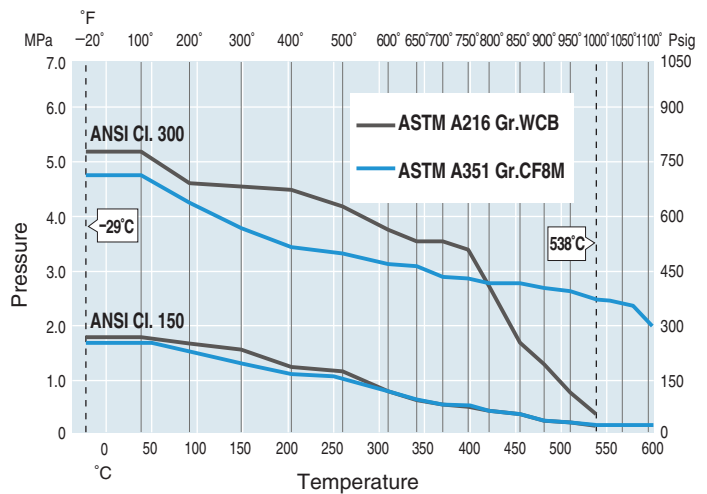

Standard Specifications

Design	API 609 Cat. B, ASME B16.34	
Nominal diameter**1	3" (80mm) to 24" (600mm)	
Pressure rating	Class 150, Class 300	
Body style	Wafer, Lugged and double flanged, short and long	
Applicable flange standard**2	ASME B16.5/JPI Class 150/300 JIS 10/16/20/30K BS4504 (DIN) PN10/16/25/40	
Face-to-face dimensions**3	Wafer, Lugged : API609 Category B Class 150/300. Double flanged : ISO 5752/API 609 Category B, double flanged short pattern Class 150/300	
Pressure-temperature rating**4	ASME B16.34 Class 150, 300lb, API609 Class 150, 300lb. Operating temperature (standard specifications): -29 to 538 degrees C (A216-WCB), -29 to 600 degrees C (A351 CF8M)	
Pressure test	Main body pressure and seat leakage test: API598. Allowable seat leakage: Preferred; API 598, ISO 5208 rate A, ANSI/FCI 70-2 Class VI. Reverse; API 598, ISO 5208 rate A, ANSI/FCI 70-2 Class VI.	
Fire safe	Fire Safe Certification based on API 607 4th / 5th Edition	
Actuator	Manual Gear, Electric, Pneumatic, Hydraulic	
Flow direction	Bi-directional (However, the standard pressure direction is for high pressure at the stem side. Selection of the drive section will differ depending on the pressure direction.)	
Applicable gaskets	Use a spiral gasket. ASME B16.5/JPI Class 150/300 commercial products may be used. Please consult us regarding JIN, BS and DIN.	
Standard materials	Body	A216 WCB or A351 CF8M
	Disc	A216 WCB or A351 CF8M
	Stem**5	A564 type 630 H1150+H1150
	Body seat	316SS / Graphite
	Disc seal**6	316SS
Coating	Silicon resin coating (Grey N7) for 200 degrees C and lower. Heat resistant silver coating for over 200 degrees C. No painting for stainless steel.	

**1 Except for 5" (125mm), 22" (550mm)
 **2 Please consult us regarding JIN, BS and DIN lugs and double flange types
 **3 Long-pattern types can be manufactured to your desired specifications
 **4 400 degrees C or less in an oxidized atmosphere
 **5 Use Inconel 718 for over 400 degrees C.
 **6 Titanium nitride hardened, Stellite #6 welding is available as an option
 ※ Valve stem position : horizontal position.

Butterfly Valve
TRITEC
TT2
334A
302A/303Q
304A/304Q
302Y/304Y
304M (HLV)
507V/508V
DTM
846T/847T/847Q
841T/842T
700Z
700G/704G/705G
700GB
731P/732P/731Q/732Q
71LG
700E/700K/700S
704G/722F/720F
KRV
227P
907H/908H (MKT)
903C

TT2 Expanded view of components

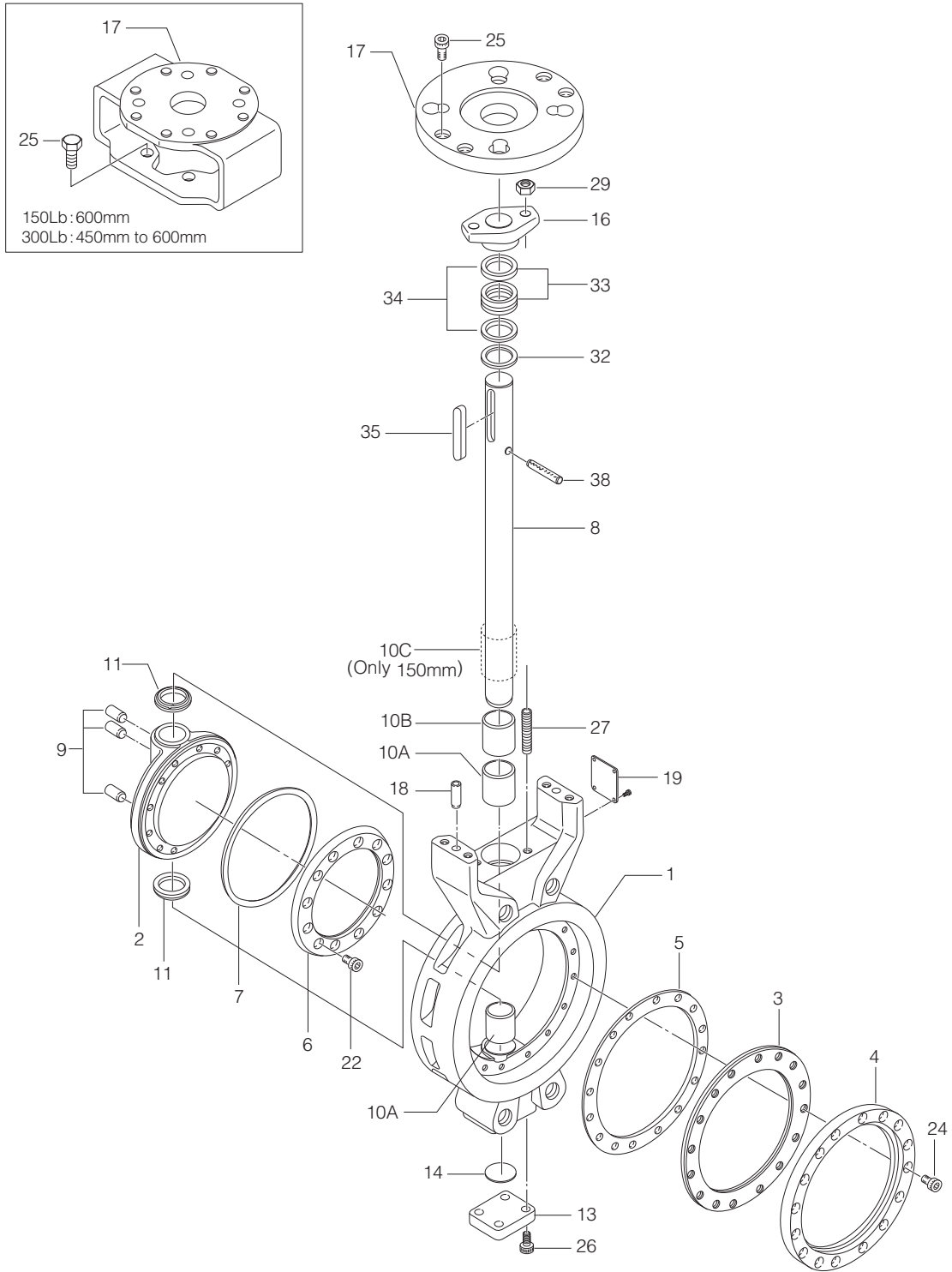

TT2 Parts list

■ TT2 Parts list (150Lb: 80mm to 500mm)
(300Lb: 80mm to 400mm)

No.	Description	Q'ty	Remarks	
1	Body	1		
2	Disc	1		
3	Body seat	1		
4	Retainer	1		
5	Body seat gasket	1		
6	Disc seal	1		
7	Disc seal gasket	1		
8	Stem	1		
9	Shaft pin	3		
10A	Bearing A	2		
10B	Bearing B	0 or 1	150Lb: 80,100mm: 1 150mm over: 0 300Lb: 1	
10C	Bearing spacer	0 or 1	150Lb: 150mm over: 1 300Lb: 150mm: 1	
11	Thrust ring	2		
13	Bottom cover	1		
14	Bottom gasket	1		
16	Glandplate spigot	1		
17	Mounting plate	1		
18	Dowel pin	2		
19	Nameplate	1		
22	Hexagon hole bolt	80mm to 200mm	4	80mm
			6	100mm
			8	150mm
		250mm to 400mm	12	200mm
			8	250mm
			12	300mm, 350mm
24	Hexagon hole bolt	80mm to 200mm	8	80mm
			12	100mm, 150mm
			16	200mm
		250mm to 400mm	20	250mm
			24	300mm
			28	350mm
32	400mm			
25	Hexagon hole bolt	4		
26	Hexagon hole bolt	4		
27	Gland bolt	2		
29	Hexagon nut	2		
32	Packing retainer	1		
33	Gland packing	3		
34	Gland packing	2		
35	Key	1		
38	Spring pin	1		

■ TT2 Parts list (150Lb: 600mm)
(300Lb: 450mm to 600mm)

No.	Description	Q'ty	Remarks
1	Body	1	
2	Disc	1	
3	Body seat	1	
4	Retainer	1	
5	Body seat gasket	1	
6	Disc seal	1	
7	Disc seal gasket	1	
8	Stem	1	
9	Shaft pin	3	
10A	BearingA	2	
10B	BearingB	1	300Lb
10C	Bearing spacer	1	150Lb
11	Thrust ring	2	
13	Bottom cover	1	
14	Bottom gasket	1	
16	Glandplate spigot	1	
17	Bracket	1	
19	Nameplate	1	
22	Hexagon hole bolt	16	450mm, 600mm
		12	500mm
24	Hexagon hole bolt	20	450mm, 500mm
		28	600mm
25	Hexagon hole bolt	4	
26	Hexagon hole bolt	4	
27	Gland bolt	2	
29	Hexagon nut	2	
32	Packing retainer	1	
33	Gland packing	3	
34	Gland packing	2	
35	Key	1	
38	Spring pin	1	

Butterfly Valve
TRITEC
TT2
334A
302A/303Q
304A/304Q
302Y/304Y
304M (HLV)
507V/508V
DTM
846T/847T/847Q
841T/842T
700Z
700G/704G/705G
700GB
731P/732P/731Q/732Q
71LG
700E/700K/700S
704G/722F/720F
KRV
227P
907H/908H (MKT)
903C

TT2-150Lb Bare shaft (Wafer type)

Nominal size		Dimension (mm)																		Approx. Mass (kg)
mm	inch	ϕd	ϕD	L	L ₁	K ₁	K ₂	H ₁	H ₂	S	a ₃	t	ϕD_1	n	BH	ϕC_1	ϕd_2	b	t ₂	
80	3	82	127	48	29	3	23.1	120.6	159	110	34	12	125	4	11	102	18	6	2.5	7
100	4	108	154	54	31.5	9	27.0	144.6	194	132	34	12	125	4	11	102	20	6	2.5	11
150	6	159	215	57	35	25.5	45.5	189.6	242	180	34	12	125	4	11	102	22	6	2.5	18
200	8	202	266	64	39	46.7	67.4	199.6	248	180	64	14	175	4	11	102	26	8	3	27
250	10	235	324	71	43	63.5	86.5	245.6	326	252	64	14	175	4	13	125	30	8	3	45
300	12	290	373	81	48.5	84	109	281.6	376	281	79	20	210	4	22	165	37	10	3	66
350	14	329	413	92	52	95.5	117.5	307.6	400	305	79	20	210	4	22	165	37	10	3	82
400	16	370	470	102	63	108.3	144.3	345.6	470	355	79	25	226	4	22	165	45	14	3.5	107
450	18	432	534	114	68	120.6	158.4	383.6	510	395	79	25	226	4	22	165	52	16	4	160
500	20	488	585	127	79	131.3	178.3	410.6	531	416	79	25	226	4	22	165	52	16	4	188
600	24	576	692	154	89	167.5	209.5	469.6	643	493	117	20	300	8	19	254	65	18	4	306

150Lb Wafer type 80mm to 500mm

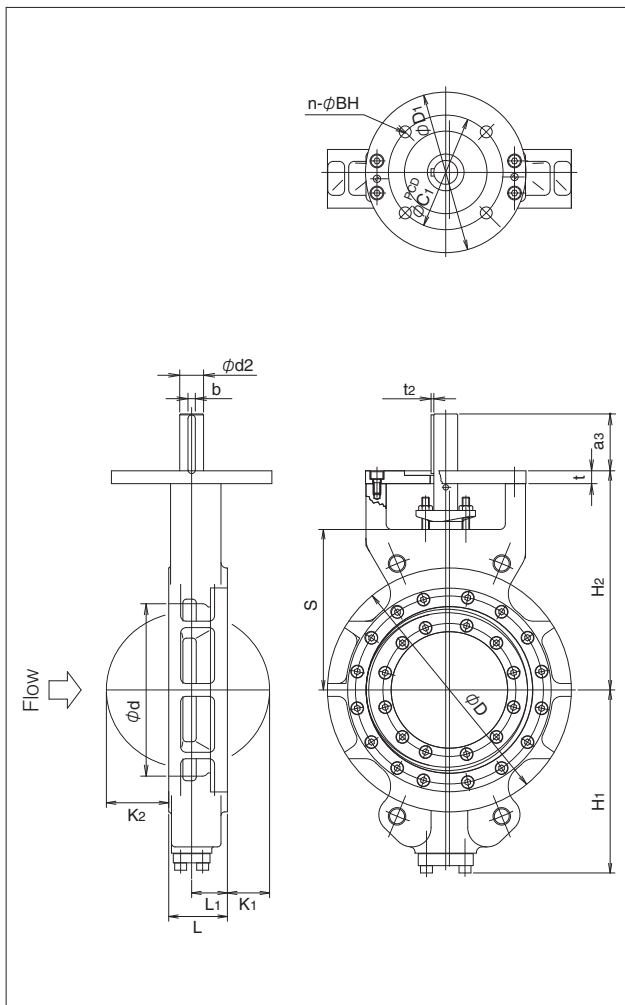

150Lb Wafer type 600mm

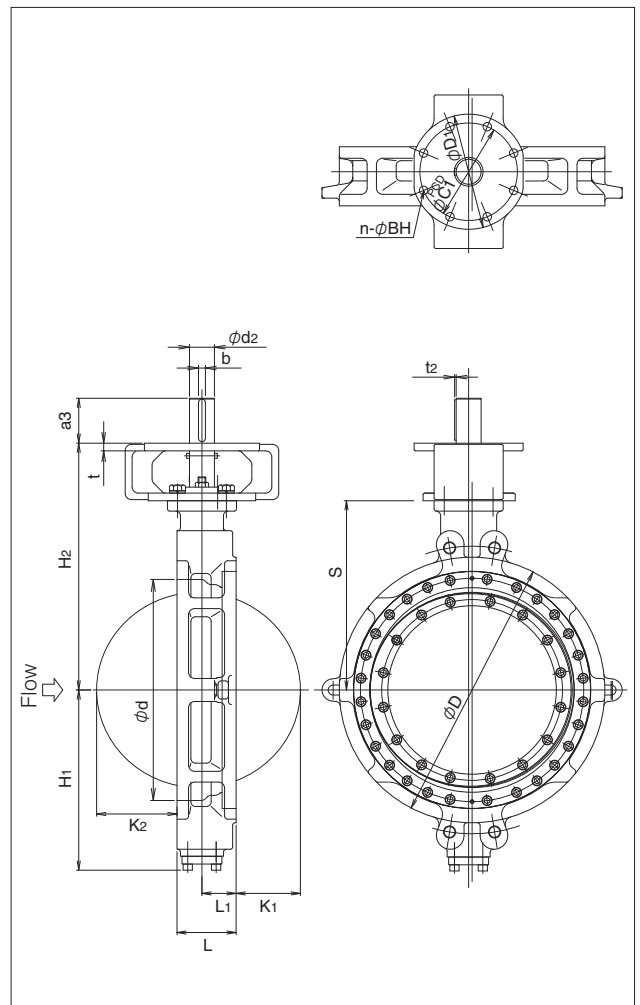

TT2-150Lb Bare shaft (Full Lugged type)

Nominal size		Dimension (mm)																			Approx. Mass (kg)	
mm	inch	ϕd	ϕD	L	L ₁	L ₃	L ₄	K ₁	K ₂	H ₁	H ₂	S	a ₃	t	ϕD_1	n	BH	ϕC_1	ϕd_2	b		t ₂
80	3	100	185	48	29	42	4	3	23.1	120.6	159	110	34	12	125	4	11	102	18	6	2.5	7
100	4	117	238	54	31.5	46.5	5	9	27	144.6	194	132	34	12	125	4	11	102	20	6	2.5	13
150	6	167	281	57	35	51.5	3.5	25.5	45.5	189.6	242	180	34	12	125	4	11	102	22	6	2.5	21
200	8	218	338	64	39	55	7	46.7	67.4	199.6	248	180	64	14	175	4	11	102	26	8	3	29
250	10	270	424	71	43	63	4	63.5	86.5	245.6	326	252	64	14	175	4	13	125	30	8	3	52
300	12	320	478	81	48.5	71	5	84	109	281.6	376	281	79	20	210	4	22	165	37	10	3	76
350	14	350	526	92	52	79	6.5	95.5	117.5	307.6	400	305	79	20	210	4	22	165	37	10	3	91
400	16	410	592	102	63	92	5	108.3	144.3	345.6	470	355	79	25	226	4	22	165	45	14	3.5	134
450	18	460	634	114	68	98	10	120.6	158.4	383.6	510	395	79	25	226	4	22	165	52	16	4	185
500	20	510	714	127	79	107	10	131.3	178.3	410.6	531	416	79	25	226	4	22	165	52	16	4	225
600	24	614	830	154	89	136	9	167.5	209.5	469.6	643	493	117	20	300	8	19	254	65	18	4	393

Butterfly Valve
TRITEC
TT2
334A
302A/303Q
304A/304Q
302Y/304Y
304M (HLV)
507V/508V
DTM
846T/847T/847Q
841T/842T
700Z
700G/704G/705G
700GB
731P/732P/731Q/732Q
71LG
700E/700K/700S
704G/722F/720F
KRV
227P
907H/908H (MKT)
903C

150Lb Full Lugged 80mm to 500mm

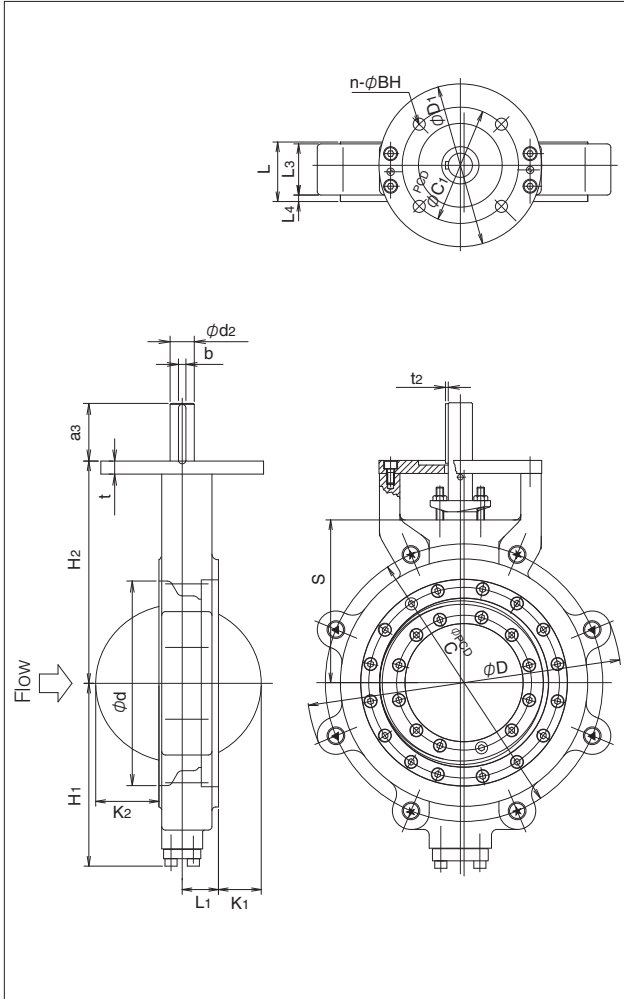

150Lb Full Lugged 600mm

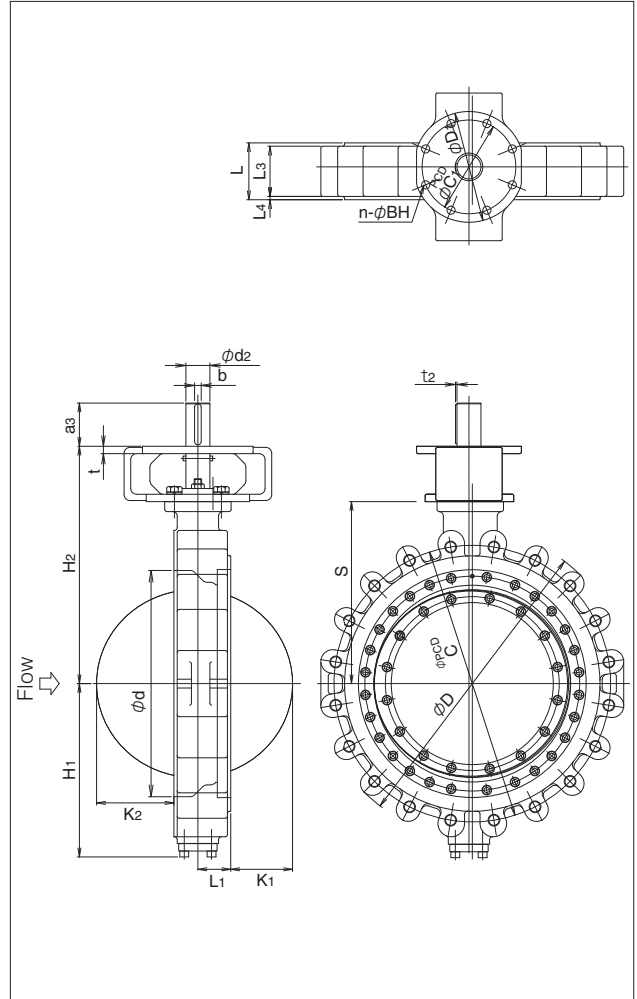

TT2-150Lb Bare shaft (Flanged type)

Nominal size		Dimension (mm)																			Approx. Mass (kg)
mm	inch	ϕd	ϕD	L	L ₁	K ₁	K ₂	T ₁	H ₁	H ₂	S	a ₃	t	ϕD_1	n	BH	ϕC_1	ϕd_2	b	t ₂	
80	3	90	190	114	29	3	0	25.5	120.6	159	110	34	12	125	4	11	102	18	6	2.5	15
100	4	117	229	127	31.5	9	0	25	144.6	194	132	34	12	125	4	11	102	20	6	2.5	21
150	6	167	279	140	35	25.5	0	27	189.6	242	180	34	12	125	4	11	102	22	6	2.5	35
200	8	218	343	152	39	46.7	0	29	199.6	248	180	64	14	175	4	11	102	26	8	3	49
250	10	270	406	165	43	63.5	0	32	245.6	326	252	64	14	175	4	13	125	30	8	3	77
300	12	320	483	178	48.5	84	12	33	281.6	376	281	79	20	210	4	22	165	37	10	3	117
350	14	350	535	190	52	95.5	19.5	36	307.6	400	305	79	20	210	4	22	165	37	10	3	155
400	16	410	595	216	63	108.3	30.3	37	345.6	470	355	79	25	226	4	22	165	45	14	3.5	194
450	18	458	635	222	68	120.6	50.4	40	383.6	510	395	79	25	226	4	22	165	52	16	4	237
500	20	510	700	229	79	131.3	76.3	43	410.6	531	416	79	25	226	4	22	165	52	16	4	312
600	24	614	815	267	89	167.5	96.5	48	469.6	643	493	117	20	300	8	19	254	65	18	4	432

150Lb Flanged 80mm to 500mm

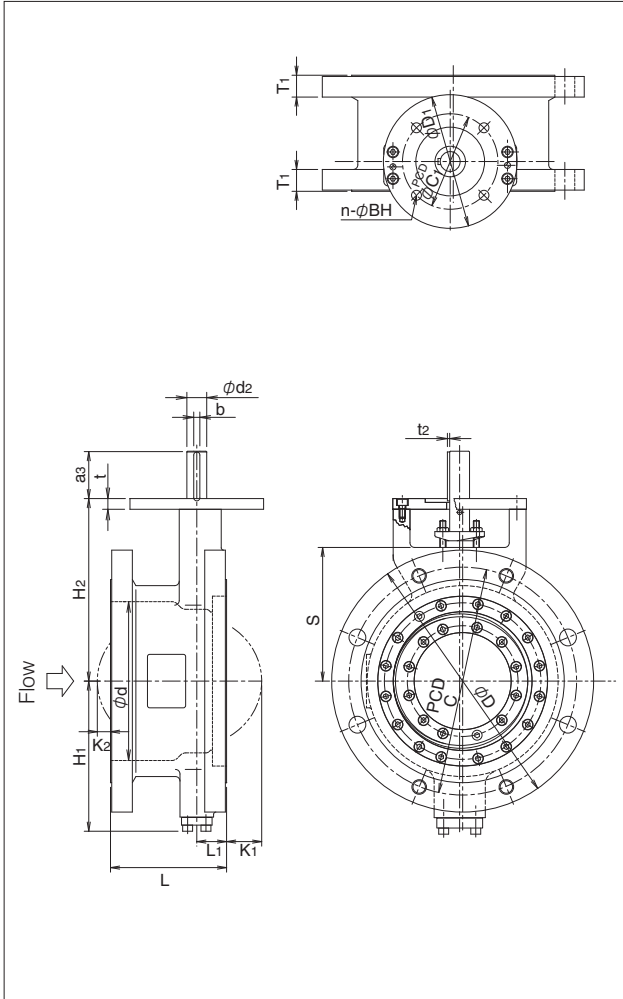

150Lb Flanged 600mm

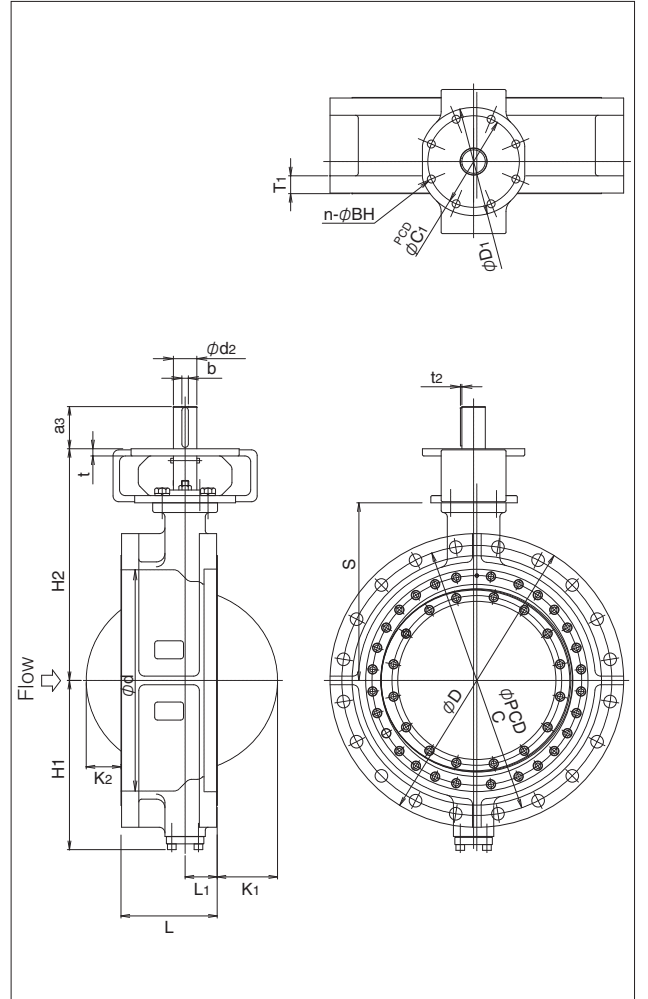

TT2-300Lb Bare shaft (Wafer type)

Nominal size		Dimension (mm)																	Approx. Mass (kg)	
mm	inch	ϕd	ϕD	L	L ₁	K ₁	K ₂	H ₁	H ₂	S	a ₃	t	ϕD_1	n	BH	ϕC_1	ϕd_2	b		t ₂
80	3	82	127	48	29	3	23.1	120.6	159	110	34	12	125	4	11	102	18	6	2.5	7
100	4	108	154	54	31.5	9	27	144.6	194	132	34	12	125	4	11	102	20	6	2.5	11
150	6	153	215	59	36.5	24	45	188.6	276	212	64	14	175	4	11	102	26	8	3	23
200	8	188	270	73	44	41.7	63.4	217.6	285	205	79	20	210	4	18	140	32	10	3	37
250	10	235	324	83	47.5	59	79	259.6	355	260	79	20	210	4	22	165	37	10	3	59
300	12	290	381	92	53	79.5	102.5	305.6	428	313	79	25	226	4	22	165	45	14	3.5	89
350	14	329	413	117	60.5	87	101	340.6	460	345	79	25	226	4	22	165	52	16	4	113
400	16	370	470	133	71	100.3	121.3	373.6	518	388	109	32	300	8	18	254	60	18	4	166
450	18	426	534	149	79	109.6	134.4	400.6	574	424	117	20	300	8	22	254	70	20	4.5	231
500	20	476	592	159	85	125.3	152.3	441.6	602	452	136	20	300	8	22	254	75	20	4.5	292
600	24	564	693	181	100	156.5	193.5	514.6	678	528	136	20	300	8	22	254	85	22	5	416

Butterfly Valve
TRITEC
TT2
334A
302A/303Q
304A/304Q
302Y/304Y
304M (HLV)
507V/508V
DTM
846T/847T/847Q
841T/842T
700Z
700G/704G/705G
700GB
731P/732P/731Q/732Q
71LG
700E/700K/700S
704G/722F/720F
KRV
227P
907H/908H (MKT)
903C

■ 300Lb Wafer 80mm to 400mm

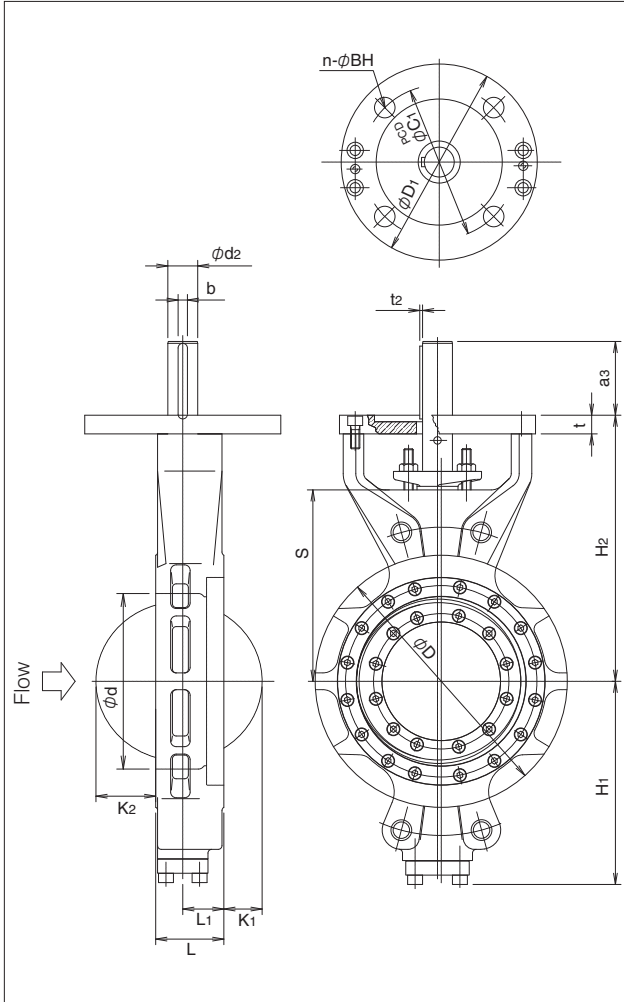

■ 300Lb Wafer 450mm to 600mm

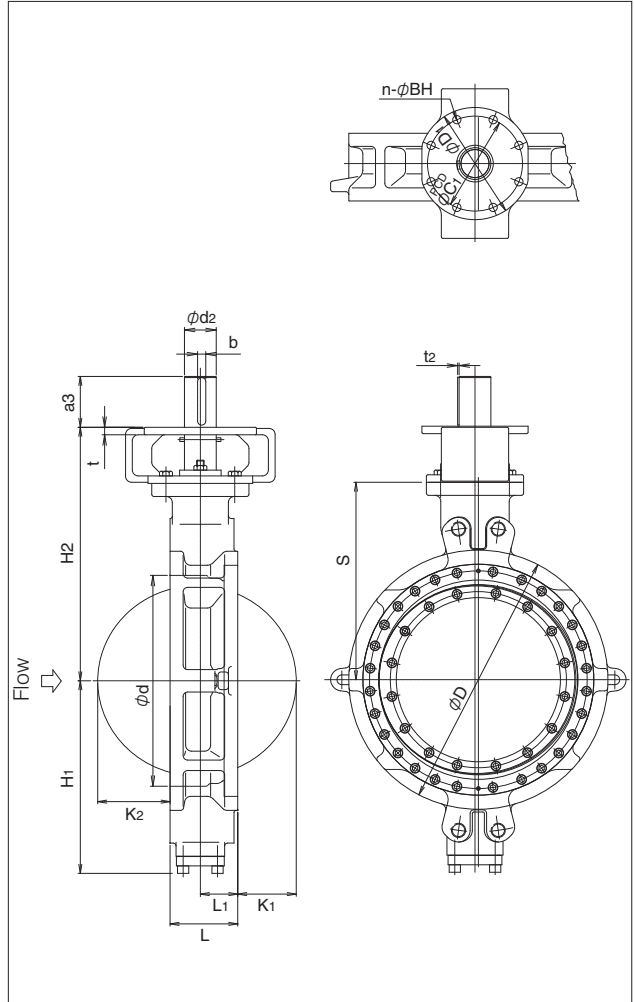

TT2-300Lb Bare shaft (Full Lugged type)

Nominal size		Dimension (mm)																				Approx. Mass (kg)
mm	inch	ϕd	ϕD	L	L ₁	L ₃	L ₄	K ₁	K ₂	H ₁	H ₂	S	a ₃	t	ϕD_1	n	BH	ϕC_1	ϕd_2	b	t ₂	
80	3	82	204	48	29	42	4	3	23.1	120.6	159	110	34	12	125	4	11	102	18	6	2.5	8.4
100	4	117	238	54	31.5	47	5	9	27	144.6	194	132	34	12	125	4	11	102	20	6	2.5	13
150	6	166	312	59	36.5	52	5	24	45	188.6	276	212	64	14	175	4	11	102	26	8	3	24
200	8	220	374	73	44	69	2	41.7	63.4	217.6	285	205	79	20	210	4	18	140	32	10	3	44
250	10	275	435	83	47.5	75	4	59	79	259.6	355	260	79	20	210	4	22	165	37	10	3	71
300	12	320	503	92	53	82	5	79.5	102.5	305.6	428	313	79	25	226	4	22	165	45	14	3.5	105
350	14	360	570	117	60.5	109	4	87	101	340.6	460	345	79	25	226	4	22	165	52	16	4	163
400	16	400	630	133	71	125	4	100.3	121.3	373.6	518	388	109	32	300	8	18	254	60	18	4	225
450	18	460	690	149	79	137	6	109.6	134.4	400.6	574	424	117	20	300	8	22	254	70	20	4.5	327
500	20	513	748	159	85	141	8	125.3	152.3	441.6	602	452	136	20	300	8	22	254	75	20	4.5	375
600	24	613	887	181	100	161	10	156.5	193.5	514.6	678	528	136	20	300	8	22	254	85	22	5	560

300Lb Full Lugged 80mm to 400mm

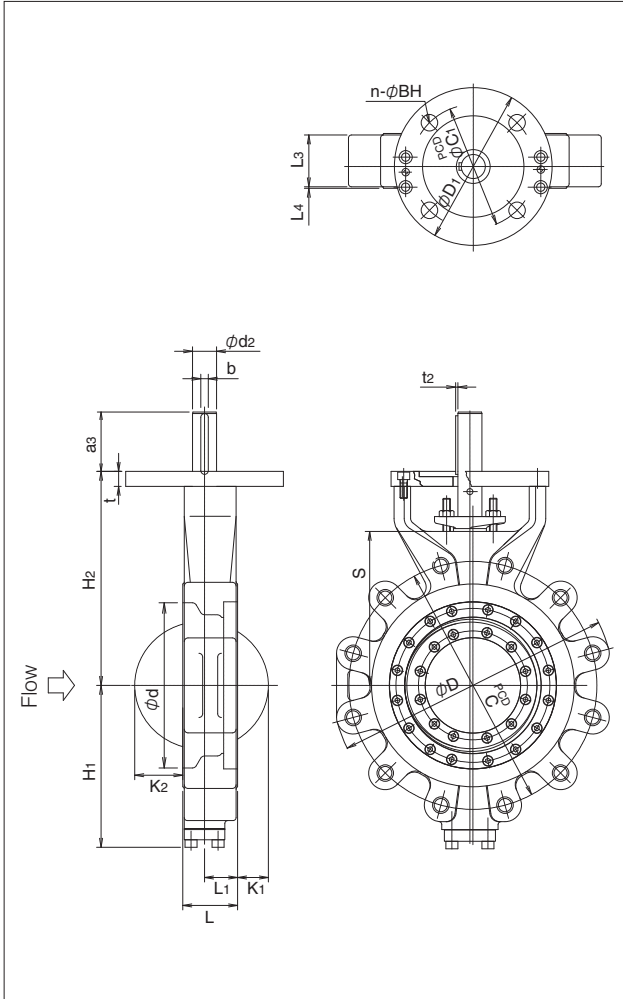

300Lb Full Lugged 450mm to 600mm

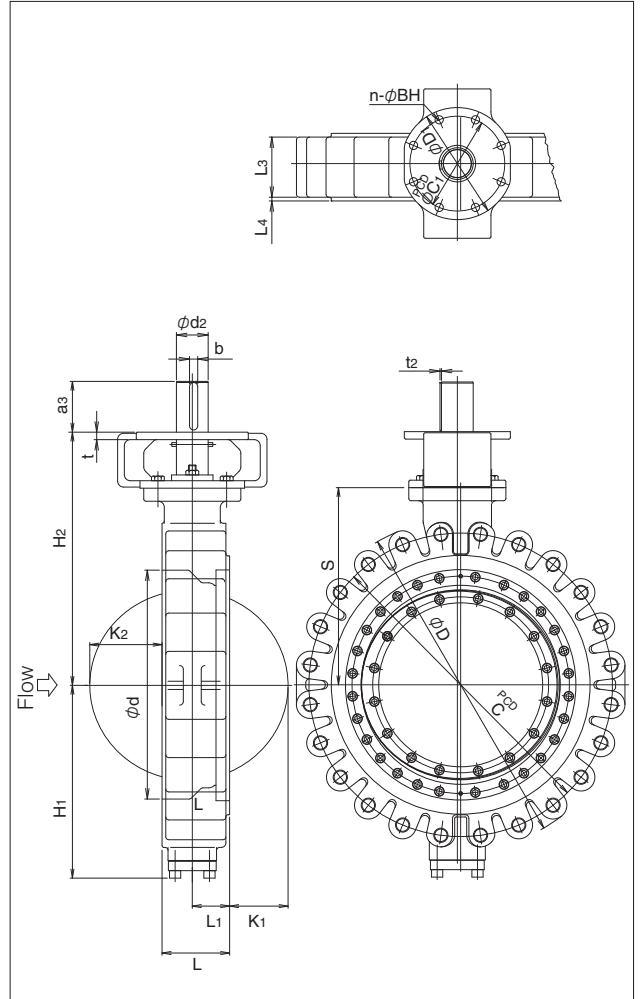

TT2-300Lb Bare shaft (Flanged type)

Nominal size		Dimension (mm)																			Approx. Mass (kg)
mm	inch	ϕd	ϕD	L	L ₁	K ₁	K ₂	T ₁	H ₁	H ₂	S	a ₃	t	ϕD_1	n	BH	ϕC_1	ϕd_2	b	t ₂	
80	3	90	210	114	29	3	0	29	120.6	159	110	34	12	125	4	11	102	18	6	2.5	17
100	4	117	254	127	31.5	9	0	32	144.6	194	132	34	12	125	4	11	102	20	6	2.5	28
150	6	166	318	140	36.5	24	0	37	188.6	276	212	64	14	175	4	11	102	26	8	3	48
200	8	208	381	152	44	41.7	0	42	217.6	285	205	79	20	210	4	18	140	32	10	3	78
250	10	275	444	165	47.5	59	0	48	259.6	355	260	79	20	210	4	22	165	37	10	3	114
300	12	310	520	178	53	79.5	16.5	51	305.6	428	313	79	25	226	4	22	165	45	14	3.5	175
350	14	360	585	190	60.5	87	28	55	340.6	460	345	79	25	226	4	22	165	52	16	4	235
400	16	410	648	216	71	100.3	38.3	58	373.6	518	388	109	32	300	8	18	254	60	18	4	302
450	18	460	710	222	79	109.6	61.4	61	400.6	574	424	117	20	300	8	22	254	70	20	4.5	407
500	20	513	775	229	85	125.3	82.3	64	441.6	602	452	136	20	300	8	22	254	75	20	4.5	491
600	24	613	915	267	100	156.5	107.5	70	514.6	678	528	136	20	300	8	22	254	85	22	5	724

Butterfly Valve
TRITEC
TT2
334A
302A/303Q
304A/304Q
302Y/304Y
304M (HLV)
507V/508V
DTM
846T/847T/847Q
841T/842T
700Z
700G/704G/705G
700GB
731P/732P/731Q/732Q
71LG
700E/700K/700S
704G/722F/720F
KRV
227P
907H/908H (MKT)
903C

■ 300Lb Flanged 80mm to 400mm

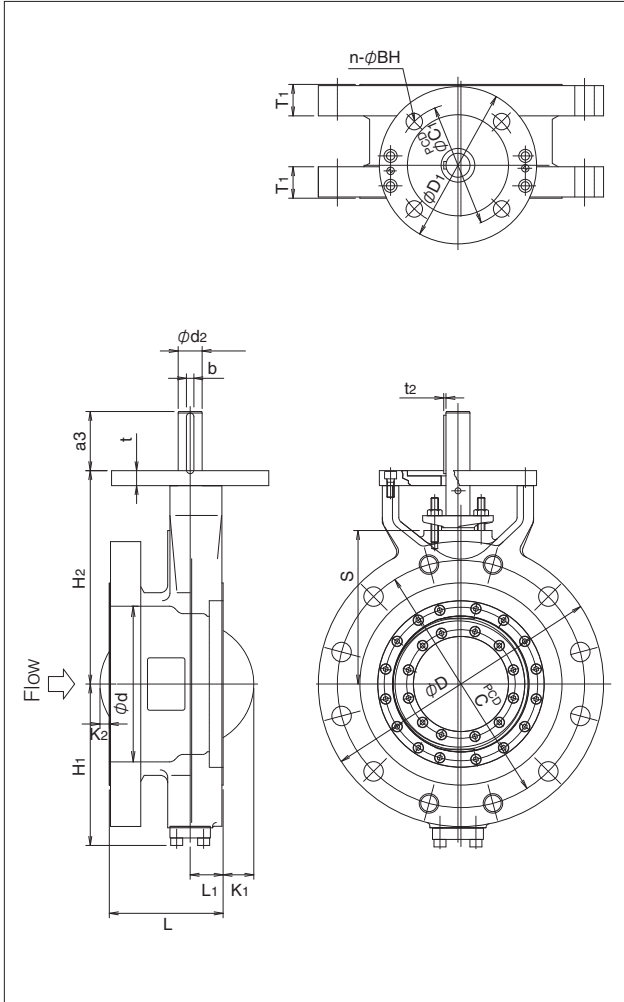

■ 300Lb Flanged 450mm to 600mm

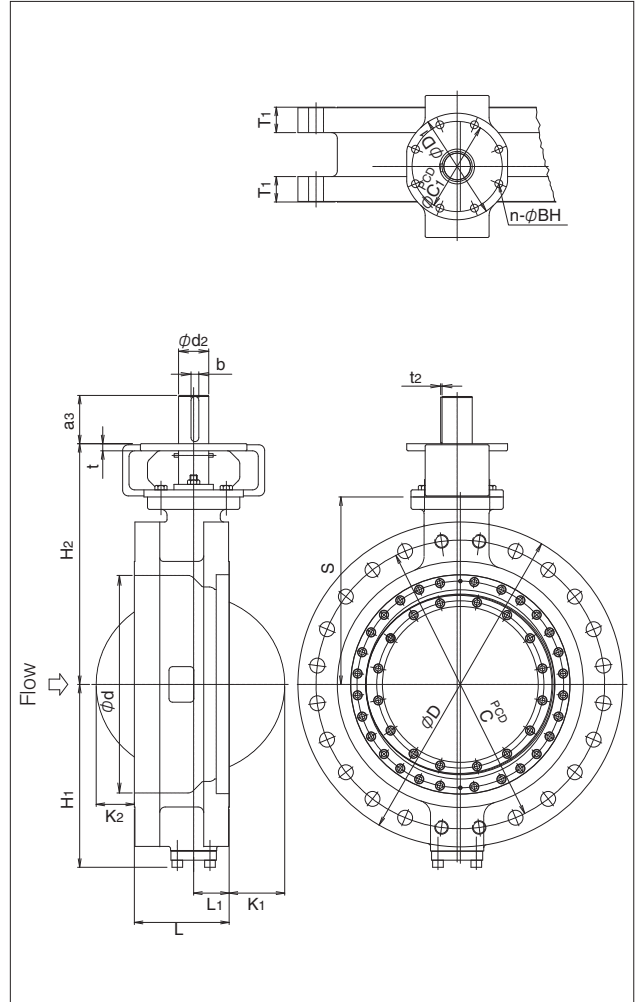

TT2 Actuator selection chart

150 Lb/300 Lb Manual Gear

Nominal size		150 Lb class (Max. pressure: 2.0MPa)		300 Lb class (Max. pressure: 5.1MPa)	
mm	inch	Gear type	Handle diameter	Gear type	Handle diameter
80	3	2U-3	200	2U-3	200
100	4			SBWG-01	370
150	6			SBWG-02	450
200	8	2U-4	280	SBWG-03	550
250	10	SBWG-02	450	SBWG-03-1S	710
300	12			SBWG-04-1S	
350	14	SBWG-03	550	SBWG-05-1S	900
400	16	SBWG-03-1S		SBWG-05-1SD	
450	18	SBWG-04-1S		SBWG-06-1SD	
500	20		710		
600	24				

150 Lb Double-action Cylinder

Nominal size		150 Lb class (Max. pressure: 2.0MPa)					
		Normal-pressure (stem) side pressurization			Reverse-pressure (retainer) side pressurization		
		Closure pressure differential			Closure pressure differential		
mm	inch	1.0 MPa or less	Over 1.0 MPa 1.5 MPa or less	Over 1.5 MPa 2.0 MPa or less	1.0 MPa or less	Over 1.0 MPa 1.5 MPa or less	Over 1.5 MPa 2.0 MPa or less
80	3	T200					
100	4	T380					
150	6	T750					
200	8	TGA-125					
250	10	TGA-140					
300	12	TGA-140			TGA-160		
350	14	TGA-140	TGA-160	TGA-160	TGA-140	TGA-160	TGA-180
400	16	TGA-160	TGA-180	TGA-180	TGA-160	TGA-180	TGA-200
450	18	TGA-180	TGA-200	TGA-200	TGA-180	TGA-200	TGA-220
500	20	TGA-200	TGA-220	TGA-250	TGA-200	TGA-220	TGA-250
600	24	TGA-200	TGA-220	TGA-250	TGA-200	TGA-220	TGA-250

TT2 Actuator Selection Chart

■ 300 Lb, Recommended pressure direction (pressure from stem side), Double-action Cylinder

Nominal size		300 Lb class (Max. pressure: 5.1 MPa)								
		Normal-pressure (stem) side pressurization								
		Closure pressure differential								
mm	inch	1.0 MPa or less	Over 1.0 MPa 1.5 MPa or less	Over 1.5 MPa 2.0 MPa or less	Over 2.0 MPa 2.5 MPa or less	Over 2.5 MPa 3.0 MPa or less	Over 3.0 MPa 3.5 MPa or less	Over 3.5 MPa 4.0 MPa or less	Over 4.0 MPa 4.5 MPa or less	Over 4.5 MPa 5.1 MPa or less
80	3	T200								
100	4	T380								
150	6	T750								
200	8	T750(TGA-125)				TGA-125				
250	10	TGA-125				TGA-140				
300	12	TGA-140			TGA-160			TGA-180		
350	14	TGA-160			TGA-180			TGA-200		
400	16	TGA-180		TGA-200		TGA-220		TGA-250		
450	18	TGA-200		TGA-220		TGA-250				
500	20	TGA-220		TGA-250						
600	24	TGA-220		TGA-250						

■ 300 Lb, Non-recommended pressure direction (pressure from retainer side), Double-action Cylinder

Nominal size		300 Lb class (Max. pressure: 5.1 MPa)								
		Reverse-pressure (retainer) side pressurization								
		Closure pressure differential								
mm	inch	1.0 MPa or less	Over 1.0 MPa 1.5 MPa or less	Over 1.5 MPa 2.0 MPa or less	Over 2.0 MPa 2.5 MPa or less	Over 2.5 MPa 3.0 MPa or less	Over 3.0 MPa 3.5 MPa or less	Over 3.5 MPa 4.0 MPa or less	Over 4.0 MPa 4.5 MPa or less	Over 4.5 MPa 5.1 MPa or less
80	3	T200								
100	4	T380								
150	6	T750								
200	8	TGA-125							TGA-140	
250	10	TGA-125							TGA-140	
300	12	TGA-160							TGA-180	
350	14	TGA-160							TGA-180	
400	16	TGA-180		TGA-200		TGA-220		TGA-250		
450	18	TGA-200		TGA-220		TGA-250				
500	20	TGA-220		TGA-250						
600	24	TGA-220		TGA-250						

Butterfly Valve
TRITEC
TT2
334A
302A/303Q
304A/304Q
302Y/304Y
304M (HLV)
507V/508V
DTM
846T/847T/847Q
841T/842T
700Z
700G/704G/705G
700GB
731P/732P/731Q/732Q
71LG
700E/700K/700S
704G/722F/720F
KRV
227P
907H/908H (MKT)
903C

TT2 Actuator Selection Chart

150Lb Single-action Cylinder

Nominal size		150 Lb class (Max. pressure: 2.0 MPa)					
		Normal-pressure (stem) side pressurization			Reverse-pressure (retainer) side pressurization		
		Closure pressure differential			Closure pressure differential		
mm	inch	1.0 MPa or less	Over 1.0 MPa 1.5 MPa or less	Over 1.5 MPa 2.0 MPa or less	1.0 MPa or less	Over 1.0 MPa 1.5 MPa or less	Over 1.5 MPa 2.0 MPa or less
80	3	T380S					
100	4	T750S					
150	6				TG-12S		
200	8						
250	10	TG-14S					
300	12						
350	14						
400	16						
450	18	TG-20S					
500	20						
600	24						

300Lb • Recommended pressure direction (pressure from stem side), Single-action Cylinder

Nominal size		300 Lb class (Max. pressure: 5.1 MPa)								
		Normal-pressure (stem) side pressurization								
		Closure pressure differential								
mm	inch	1.0 MPa or less	Over 1.0 MPa 1.5 MPa or less	Over 1.5 MPa 2.0 MPa or less	Over 2.0 MPa 2.5 MPa or less	Over 2.5 MPa 3.0 MPa or less	Over 3.0 MPa 3.5 MPa or less	Over 3.5 MPa 4.0 MPa or less	Over 4.0 MPa 4.5 MPa or less	Over 4.5 MPa 5.1 MPa or less
80	3	T750S								
100	4	TG-10S								
150	6	TG-12S								
200	8	TG-14S								
250	10									
300	12	TG-20S								
350	14									
400	16									
450	18									
500	20									
600	24									

TT2 Actuator Selection Chart

■ 300Lb • Non-recommended pressure direction (pressure from retainer side), Single-action Cylinder

Nominal size		300 Lb class (Max. pressure: 5.1 MPa)								
		Reverse-pressure (retainer) side pressurization								
		Closure pressure differential								
mm	inch	1.0 MPa or less	Over 1.0 MPa 1.5 MPa or less	Over 1.5 MPa 2.0 MPa or less	Over 2.0 MPa 2.5 MPa or less	Over 2.5 MPa 3.0 MPa or less	Over 3.0 MPa 3.5 MPa or less	Over 3.5 MPa 4.0 MPa or less	Over 4.0 MPa 4.5 MPa or less	Over 4.5 MPa 5.1 MPa or less
80	3	T750S								
100	4	TG-10S								
150	6	TG-12S								
200	8	TG-14S								
250	10	TG-14S								
300	12	TG-20S								
350	14	TG-20S								

Butterfly Valve
TRITEC
TT2
334A
302A/303Q
304A/304Q
302Y/304Y
304M (HLV)
507V/508V
DTM
846T/847T/847Q
841T/842T
700Z
700G/704G/705G
700GB
731P/732P/731Q/732Q
71LG
700E/700K/700S
704G/722F/720F
KRV
227P
907H/908H (MKT)
903C

TT2 Actuator Mounting Finished by Temperature

■ 300Lb-80 to 400mm, 150Lb-80 to 500mm

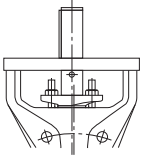
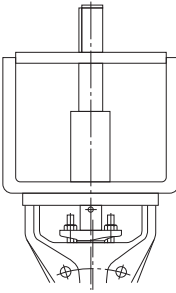
	
-29 to 400 degrees C	400 to 600 degrees C
Body / Disc	A216 WCB (-29 to 538 degrees C) A351 CF8M (-29 to 600 degrees C)
Disc seal	316SS
Stem	A564-630 (H1150×2) Inconel 718
Body seat	316SS + graphite laminate

■ 300Lb-450 to 600mm, 150Lb-600mm

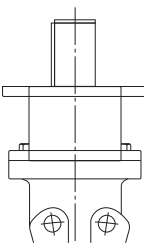
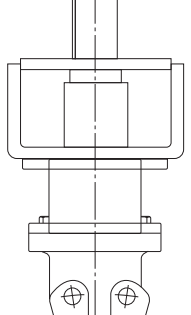
	
-29 to 400 degrees C	400 to 600 degrees C
Body / Disc	A216 WCB (-29 to 538 degrees C) A351 CF8M (-29 to 600 degrees C)
Disc seal	316SS
Stem	A564-630 (H1150×2) Inconel 718
Body seat	316SS + graphite laminate

TT2 150Lb Cv value/pressure loss coefficient

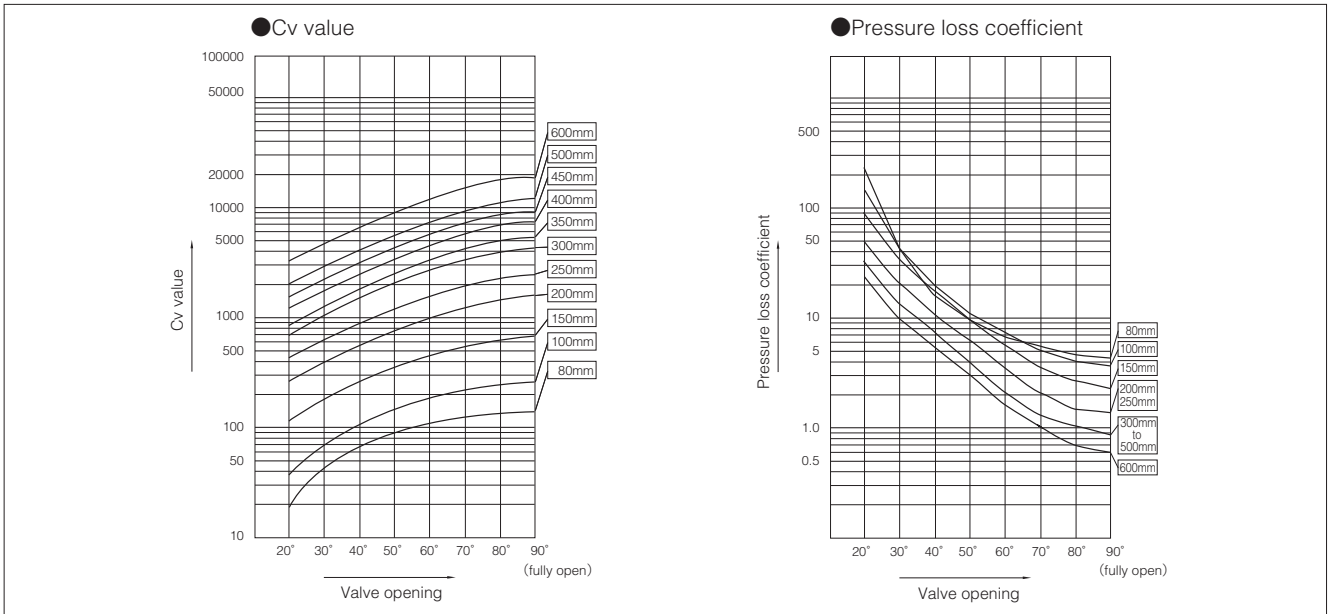

TT2 150Lb Cv value

Nominal size		Valve opening							
mm	inch	20°	30°	40°	50°	60°	70°	80°	90°
80	3	18.5	42.9	69.8	92.5	109	121	130	134
100	4	38.9	73.1	109	146	182	217	244	255
150	6	111	181	253	340	446	559	650	686
200	8	259	400	542	730	980	1260	1480	1570
250	10	411	635	859	1160	1550	1990	2340	2480
300	12	697	1080	1460	1960	2630	3370	3970	4210
350	14	861	1330	1800	2420	3250	4170	4910	5200
400	16	1200	1850	2510	3370	4530	5810	6840	7250
450	18	1500	2310	3130	4220	5670	7270	8550	9060
500	20	1930	2980	4040	5440	7310	9360	11000	11700
600	24	3110	4800	6500	8750	11800	15100	17700	18800

TT2 150Lb Pressure loss coefficient

Nominal size		Valve opening							
mm	inch	20°	30°	40°	50°	60°	70°	80°	90°
80	3	233	43.2	16.3	9.29	6.71	5.47	4.69	4.45
100	4	155	43.9	19.5	11.0	7.04	4.99	3.92	3.6
150	6	90.4	33.9	17.3	9.6	5.58	3.56	2.63	2.36
200	8	50.8	21.3	11.6	6.41	3.55	2.16	1.56	1.39
250	10	48.5	20.3	11.1	6.12	3.39	2.07	1.49	1.33
300	12	34.7	14.6	7.95	4.38	2.43	1.48	1.07	0.95
350	14	35.7	15	8.17	4.5	2.50	1.52	1.1	0.976
400	16	31.3	13.2	7.18	3.96	2.19	1.34	0.964	0.858
450	18	32.1	13.5	7.35	4.05	2.24	1.37	0.987	0.878
500	20	29.8	12.5	6.83	3.76	2.09	1.27	0.917	0.817
600	24	24.1	10.1	5.52	3.04	1.69	1.03	0.741	0.66

TT2 300Lb Cv value/pressure loss coefficient

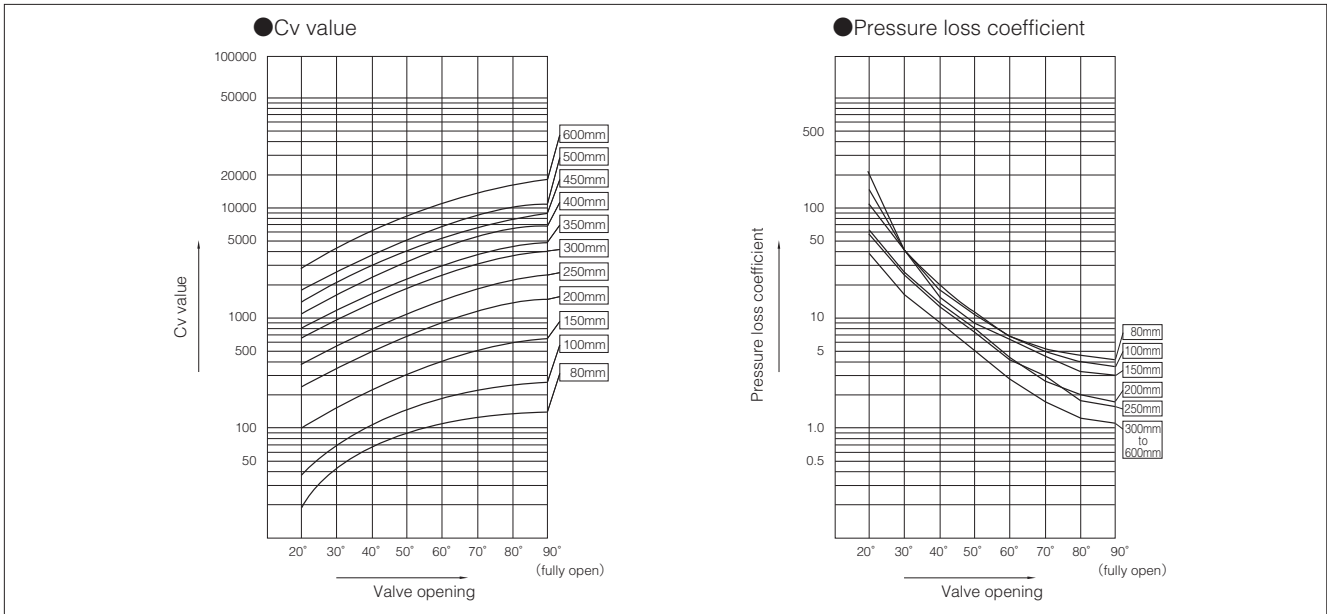

Butterfly Valve
TRITEC
TT2
334A
302A/303Q
304A/304Q
302Y/304Y
304M (HLV)
507V/508V
DTM
846T/847T/847Q
841T/842T
700Z
700G/704G/705G
700GB
731P/732P/731Q/732Q
71LG
700E/700K/700S
704G/722F/720F
KRV
227P
907H/908H (MKT)
903C

TT2 300Lb Cv value

Nominal size		Valve opening							
mm	inch	20°	30°	40°	50°	60°	70°	80°	90°
80	3	18.5	42.9	69.8	92.5	109	121	130	134
100	4	38.9	73.1	109	146	182	217	244	255
150	6	99	162	226	304	399	499	580	612
200	8	232	357	484	652	875	1120	1320	1400
250	10	367	567	767	1030	1390	1780	2090	2220
300	12	622	960	1300	1750	2350	3010	3550	3760
350	14	768	1190	1610	2160	2910	3270	4380	4640
400	16	1070	1650	2240	3010	4050	5190	6100	6470
450	18	1340	2070	2800	3770	5060	6490	7630	8090
500	20	1730	2660	3610	4860	6520	8360	9840	10400
600	24	2780	4290	5800	7820	10500	13500	15800	16800

TT2 300Lb Pressure loss coefficient

Nominal size		Valve opening							
mm	inch	20°	30°	40°	50°	60°	70°	80°	90°
80	3	233	43.2	16.3	9.29	6.71	5.47	4.69	4.45
100	4	155	43.9	19.5	11.0	7.04	4.99	3.92	3.6
150	6	113	42.5	21.7	12.0	7.00	4.46	3.3	2.97
200	8	63.7	26.7	14.6	8.04	4.46	2.71	1.96	1.74
250	10	60.8	25.5	13.9	7.67	4.25	2.59	1.87	1.66
300	12	43.5	18.3	9.97	5.49	3.05	1.85	1.34	1.19
350	14	44.7	18.8	10.2	5.65	3.13	1.91	1.38	1.22
400	16	39.3	16.5	9	4.96	2.75	1.67	1.21	1.08
450	18	40.3	16.9	9.22	5.08	2.82	1.71	1.24	1.1
500	20	37.4	15.7	8.57	4.72	2.62	1.59	1.15	1.02
600	24	30.2	12.7	6.92	3.81	2.11	1.29	0.929	0.827

TT2 KC, FL

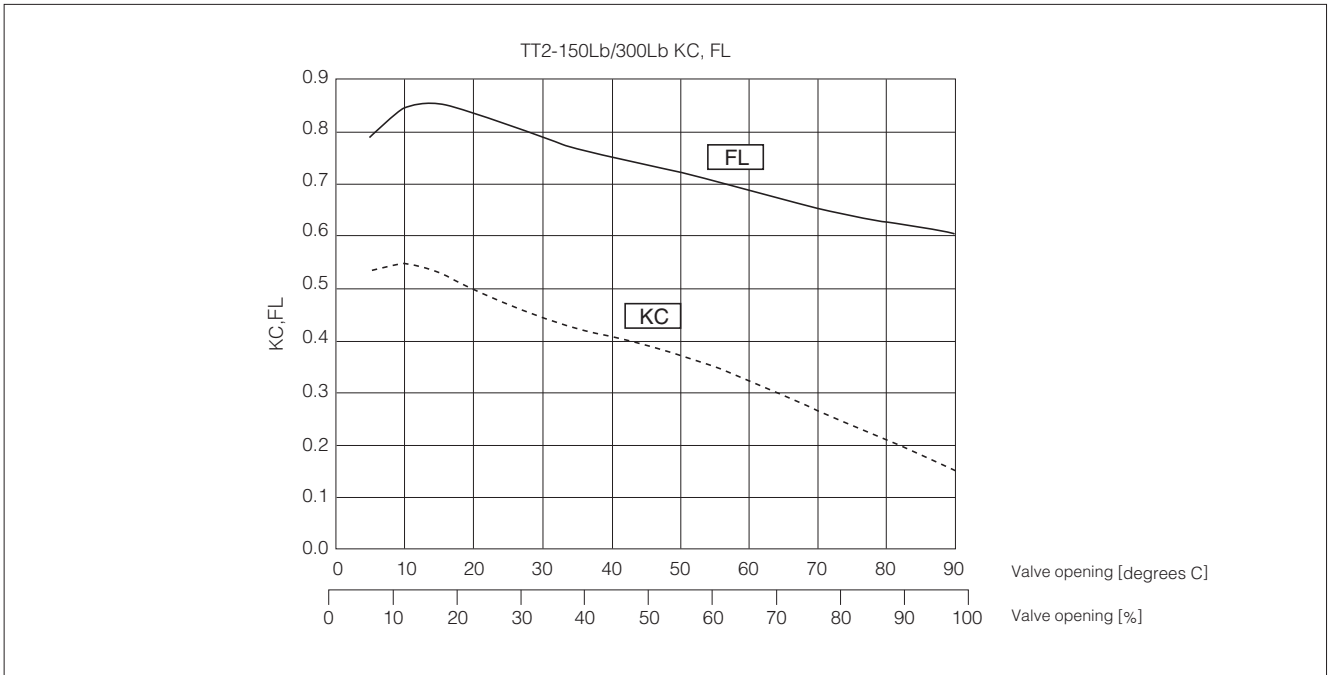

150Lb, 300Lb

mm	Valve opening							
	20°	30°	40°	50°	60°	70°	80°	90°
KC	0.498	0.443	0.407	0.372	0.324	0.265	0.209	0.151
FL	0.838	0.788	0.752	0.724	0.691	0.654	0.626	0.604

TT2 Minimum internal diameters of piping

Nominal size		Minimum internal diameters of piping	
mm	inch	150Lb	300Lb
80	3	73	73
100	4	87	87
150	6	129	128
200	8	185	181
250	10	227	221
300	12	281	275
350	14	313	301
400	16	363	349
450	18	395	385
500	20	446	430
600	24	538	534

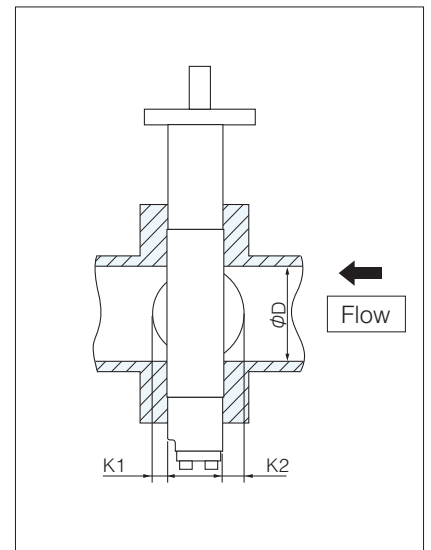

Worm gear type TT2-2U(80mm to 250mm) / TT2-2K(300mm to 600mm)

150Lb Wafer type High temperature specification

Nominal size		Dimension (mm)														Gear type	Approx. Mass (kg)
mm	inch	ϕd	ϕD	L	L ₂	H ₁	H ₂	S	H ₃	H ₄	E	K	F	ϕW			
80	3	82	127	48	19	120.6	159	110	42	100	67	75	198	200	2U-3	19 (15)	
100	4	108	154	54	22.5	144.6	194	132	42	100	67	75	198	200	2U-3	23 (19)	
150	6	159	215	57	22	189.6	242	180	42	100	67	75	198	200	2U-3	30 (26)	
200	8	202	266	64	25	199.6	248	180	42	100	67	88	198	200	2U-3	39 (35)	
250	10	235	324	71	28	245.6	326	252	48	150	88	90	223	280	2U-4	67 (61)	
300	12	290	373	81	32.5	281.6	376	281	63	150	91.5	127	310	450	SBWG-02	103 (87)	
350	14	329	413	92	40	307.6	400	305	63	150	91.5	127	310	450	SBWG-02	119 (103)	
400	16	370	470	102	39	345.6	470	355	63	180	113	156	343	550	SBWG-03	155 (135)	
450	18	432	534	114	46	383.6	510	395	63	180	31.5	156	363	550	SBWG-03-1S	214 (194)	
500	20	488	585	127	48	410.6	531	416	63	180	31.5	156	363	550	SBWG-03-1S	241 (221)	
600	24	576	692	154	65	469.6	643	493	85	200	32.7	200	422	710	SBWG-04-1S	411 (381)	

() Standard

TT2-2U/2K

80 to 250mm

300 to 500mm

600mm

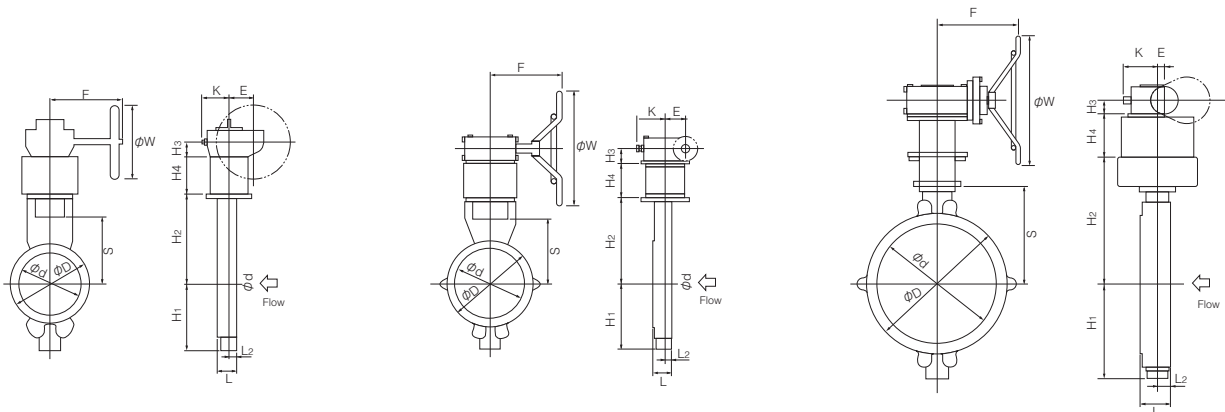

2U/2K Installation direction

<p>Stem side</p> <p>Retainer side</p>	<p>Stem side</p> <p>Retainer side</p>	<p>Stem side</p> <p>Retainer side</p>	<p>Stem side</p> <p>Retainer side</p>
2UA / 2KA	2UB / 2KB	2UC / 2KC	2UD / 2KD

Butterfly Valve
TRITEC
TT2
334A
302A/303Q
304A/304Q
302Y/304Y
304M (HLV)
507V/508V
DTM
846T/847T/847Q
841T/842T
700Z
700G/704G/705G
700GB
731P/732P/731Q/732Q
71LG
700E/700K/700S
704G/722F/720F
KRV
227P
907H/908H (MKT)
903C

Worm Gear Type TT2-2U(80mm to 250m) / TT2-2K(300mm to 600mm)

150Lb Full Lugged Type in High Temperature Specification

Nominal size		Dimension (mm)													Gear type	Approx. Weight (kg)
mm	inch	ϕd	ϕD	L	L ₂	H ₁	H ₂	S	H ₃	H ₄	E	K	F	ϕW		
80	3	100	185	48	19	120.6	159	110	42	100	67	75	198	200	2U-3	19 (15)
100	4	117	238	54	22.5	144.6	194	132	42	100	67	75	198	200	2U-3	25 (21)
150	6	167	281	57	22	189.6	242	180	42	100	67	75	198	200	2U-3	32 (28)
200	8	218	338	64	25	199.6	248	180	42	100	67	88	198	200	2U-3	40 (36)
250	10	270	424	71	28	245.6	326	252	48	150	88	90	222.5	280	2U-4	74 (68)
300	12	320	478	81	32.5	281.6	376	281	63	150	91.5	127	310	450	SBWG-02	113 (97)
350	14	350	526	92	40	307.6	400	305	63	150	91.5	127	310	450	SBWG-02	128 (112)
400	16	410	592	102	39	345.6	470	355	63	180	113	156	343	550	SBWG-03	182 (162)
450	18	460	634	114	46	383.6	510	395	63	180	31.5	156	363	550	SBWG-03-1S	238 (218)
500	20	510	714	127	48	410.6	531	416	63	180	31.5	156	363	550	SBWG-03-1S	278 (258)
600	24	614	830	154	65	496.6	643	493	85	200	32.7	200	422	710	SBWG-04-1S	498 (468)

() Standard

TT2-2U/2K

80 to 250mm

300 to 500mm

600mm

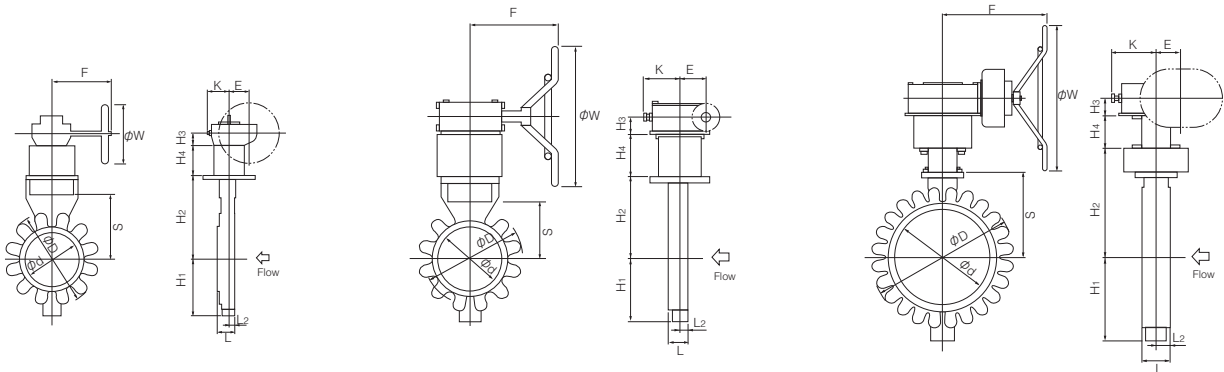

2U/2K Installation Direction

<p>Stem Side</p> <p>Retainer Side</p> <p>2UA / 2KA</p>	<p>Stem Side</p> <p>Retainer Side</p> <p>2UB / 2KB</p>	<p>Stem Side</p> <p>Retainer Side</p> <p>2UC / 2KC</p>	<p>Stem Side</p> <p>Retainer Side</p> <p>2UD / 2KD</p>
--------------------------------------------------------	--------------------------------------------------------	--------------------------------------------------------	--------------------------------------------------------

Worm Gear Type TT2-2U(80mm to 250mm) / TT2-2K(300mm to 600mm)

■ 150Lb Flanged Type in High Temperature Specification

Nominal size		Dimension (mm)													Gear type	Approx. Weight (kg)
mm	inch	ϕd	ϕD	L	L ₂	H ₁	H ₂	S	H ₃	H ₄	E	K	F	ϕW		
80	3	90	190	114	85	120.6	159	110	42	100	67	75	198	200	2U-3	26 (22)
100	4	117	229	127	95.5	144.6	194	132	42	100	67	75	198	200	2U-3	33 (29)
150	6	167	279	140	105	189.6	242	180	42	100	67	75	198	200	2U-3	46 (42)
200	8	218	343	152	113	199.6	248	180	42	100	67	88	198	200	2U-3	60 (56)
250	10	270	406	165	122	245.6	326	252	48	150	88	90	222.5	280	2U-4	99 (93)
300	12	320	483	178	129.5	281.6	376	281	63	150	91.5	127	310	450	SBWG-02	154 (138)
350	14	350	535	190	138	307.6	400	305	63	150	91.5	127	310	450	SBWG-02	192 (176)
400	16	410	595	216	153	345.6	470	355	63	180	113	156	343	550	SBWG-03	242 (222)
450	18	458	635	222	154	383.6	510	395	63	180	31.5	156	363	550	SBWG-03-1S	290 (270)
500	20	510	700	229	150	410.6	531	416	63	180	31.5	156	363	550	SBWG-03-1S	365 (345)
600	24	614	815	267	178	469.6	643	493	85	200	32.7	200	422	710	SBWG-04-1S	537 (507)

() Standard

■ TT2-2U/2K

80 to 250mm

300 to 500mm

600mm

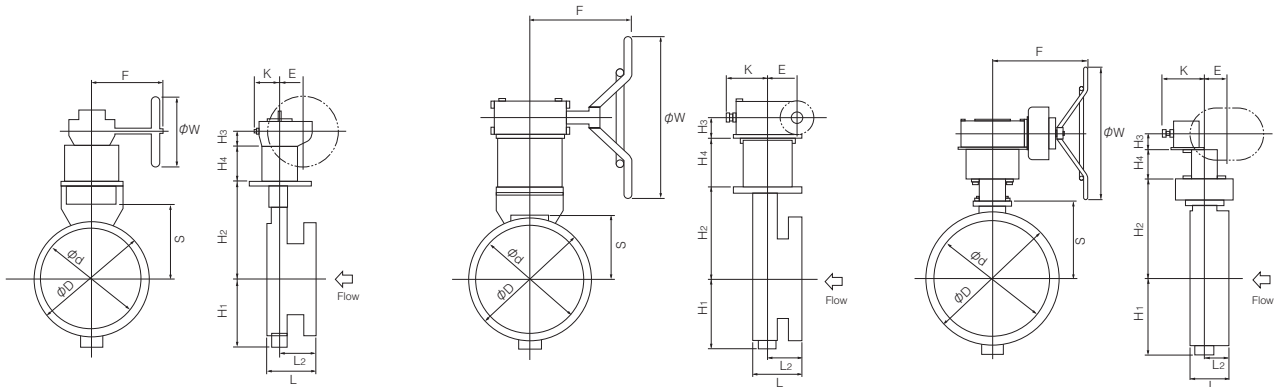

■ 2U/2K Installation Direction

<p>Stem Side</p> <p>Retainer Side</p>	<p>Stem Side</p> <p>Retainer Side</p>	<p>Stem Side</p> <p>Retainer Side</p>	<p>Stem Side</p> <p>Retainer Side</p>
2UA / 2KA	2UB / 2KB	2UC / 2KC	2UD / 2KD

Butterfly Valve
TRITEC
TT2
334A
302A/303Q
304A/304Q
302Y/304Y
304M (HLV)
507V/508V
DTM
846T/847T/847Q
841T/842T
700Z
700G/704G/705G
700GB
731P/732P/731Q/732Q
71LG
700E/700K/700S
704G/722F/720F
KRV
227P
907H/908H (MKT)
903C

Worm Gear Type TT2-2U(80mm to 150mm) / TT2-2K(200mm to 600mm)

300Lb Waefr Type in High Temperature Specification

Nominal size		Dimension (mm)													Gear type	Approx. Weight (kg)
mm	inch	ϕd	ϕD	L	L ₂	H ₁	H ₂	S	H ₃	H ₄	E	K	F	ϕW		
80	3	82	127	48	19	120.6	159	110	42	100	67	75	198	200	2U-3	19 (15)
100	4	108	154	54	22.5	144.6	194	132	42	100	67	75	198	200	2U-3	23 (19)
150	6	153	215	59	22.5	188.6	276	212	42	100	67	88	198	200	2U-3	35 (31)
200	8	188	270	73	29	217.6	285	205	52	150	75	110	252	370	SBWG-01	61 (49)
250	10	235	324	83	35.5	259.6	355	260	63	150	91.5	127	310	450	SBWG-02	96 (80)
300	12	290	381	92	39	305.6	428	313	63	180	113	156	343	550	SBWG-03	137 (117)
350	14	329	413	117	56.5	340.6	460	345	63	180	31.5	156	363	550	SBWG-03-1S	166 (146)
400	16	370	470	133	62	373.6	518	388	85	200	32.7	180	422	710	SBWG-04-1S	268 (238)
450	18	426	534	149	70	400.6	574	424	87	200	72.7	216	476	710	SBWG-05-1S	366 (329)
500	20	476	592	159	74	441.6	602	452	87	200	184.5	218	508	710	SBWG-05-1SD	436 (399)
600	24	564	693	181	81	514.6	678	528	110	200	230	290	648	900	SBWG-06-1SD	673 (636)

() Standard

TT2-2U/2K

80 to 150mm

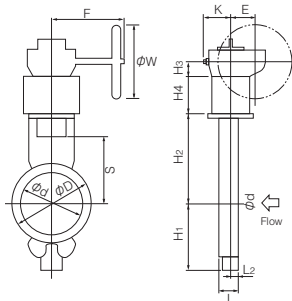

200 to 400mm

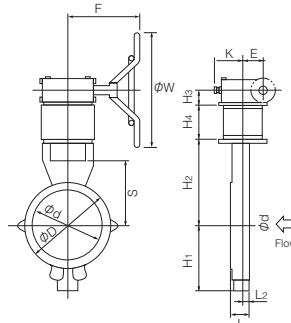

450 to 600mm

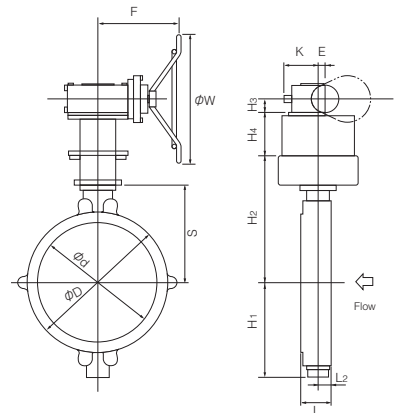

2U/2K Installation Direction

<p>Stem Side</p> <p>Retainer Side</p> <p>2UA / 2KA</p>	<p>Stem Side</p> <p>Retainer Side</p> <p>2UB / 2KB</p>	<p>Stem Side</p> <p>Retainer Side</p> <p>2UC / 2KC</p>	<p>Stem Side</p> <p>Retainer Side</p> <p>2UD / 2KD</p>
--------------------------------------------------------	--------------------------------------------------------	--------------------------------------------------------	--------------------------------------------------------

Worm Gear Type TT2-2U(80mm to 150mm) / TT2-2K(200mm to 600mm)

■300Lb Full Lugged Type in High Temperature Specification

Nominal size		Dimension (mm)													Gear type	Approx. Weight (kg)
mm	inch	ϕd	ϕD	L	L ₂	H ₁	H ₂	S	H ₃	H ₄	E	K	F	ϕW		
80	3	82	204	48	19	120.6	159	110	42	100	67	75	198	200	2U-3	20 (16)
100	4	177	238	54	22.5	144.6	194	132	42	100	67	75	198	200	2U-3	25 (21)
150	6	166	312	59	22.5	188.6	276	212	42	100	67	88	198	200	2U-3	36 (32)
200	8	220	374	73	29	217.6	285	205	52	150	75	110	252	370	SBWG-01	72 (56)
250	10	275	435	83	35.5	259.6	355	260	63	150	91.5	127	310	450	SBWG-02	108 (92)
300	12	320	503	92	39	305.6	428	313	63	180	113	156	343	550	SBWG-03	153 (133)
350	14	360	570	117	56.5	340.6	460	345	63	180	31.5	156	363	550	SBWG-03-1S	216 (196)
400	16	400	630	133	62	373.6	518	388	85	200	32.7	180	422	710	SBWG-04-1S	327 (297)
450	18	460	690	149	70	400.6	574	424	87	200	72.7	216	476	710	SBWG-05-1S	462 (425)
500	20	513	748	159	74	441.6	602	452	87	200	184.5	218	508	710	SBWG-05-1SD	519 (482)
600	24	613	887	181	81	514.6	678	528	110	200	230	290	648	900	SBWG-06-1SD	817 (780)

() Standard

■TT2-2U/2K

80 to 150mm

200 to 400mm

450 to 600mm

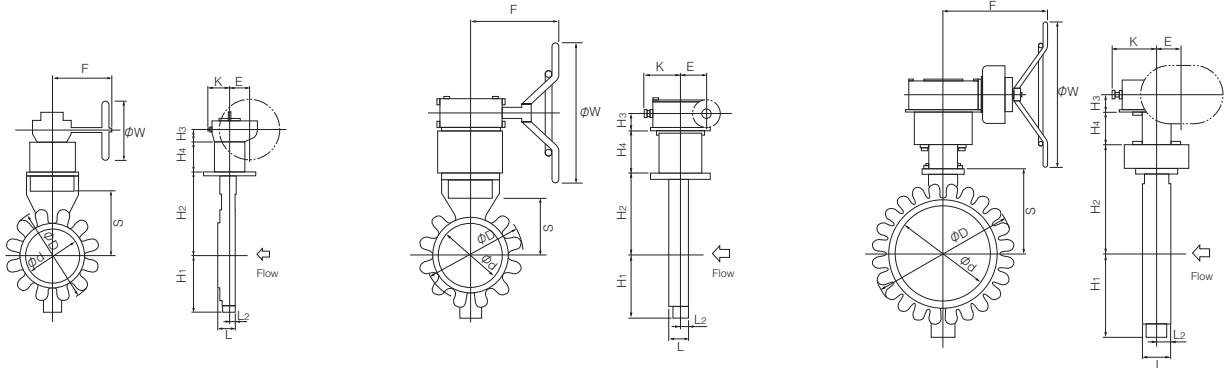

■2U/2K Installation Direction

<p>Stem Side</p> <p>Retainer Side</p>	<p>Stem Side</p> <p>Retainer Side</p>	<p>Stem Side</p> <p>Retainer Side</p>	<p>Stem Side</p> <p>Retainer Side</p>
2UA / 2KA	2UB / 2KB	2UC / 2KC	2UD / 2KD

Butterfly Valve
TRITEC
TT2
334A
302A/303Q
304A/304Q
302Y/304Y
304M (HLV)
507V/508V
DTM
846T/847T/847Q
841T/842T
700Z
700G/704G/705G
700GB
731P/732P/731Q/732Q
71LG
700E/700K/700S
704G/722F/720F
KRV
227P
907H/908H (MKT)
903C

Worm Gear Type TT2-2U(80mm to 150mm) / TT2-2K(200mm to 600mm)

300Lb Flanged Type in High Temperature Specification

Nominal size		Dimension (mm)													Gear type	Approx. Weight (kg)
mm	inch	ϕd	ϕD	L	L_2	H_1	H_2	S	H_3	H_4	E	K	F	ϕW		
80	3	90	210	114	85	120.6	159	110	42	100	67	75	198	200	2U-3	29 (25)
100	4	117	254	127	95.5	144.6	194	132	42	100	67	75	198	200	2U-3	40 (36)
150	6	166	318	140	103.5	188.6	276	212	42	100	67	88	198	200	2U-3	60 (56)
200	8	208	381	152	108	217.6	285	205	52	150	75	110	252	370	SBWG-01	102 (90)
250	10	275	444	165	117.5	259.6	355	260	63	150	91.5	127	310	450	SBWG-02	151 (135)
300	12	310	520	178	125	305.6	428	313	63	180	113.0	156	343	550	SBWG-03	223 (203)
350	14	360	585	190	129.5	340.6	460	345	63	180	31.5	156	363	550	SBWG-03-1S	288 (268)
400	16	410	648	216	145	373.6	518	388	85	200	32.7	180	422	710	SBWG-04-1S	404 (374)
450	18	460	710	222	143	400.6	574	424	87	200	72.7	216	476	710	SBWG-05-1S	542 (505)
500	20	513	775	229	144	441.6	602	452	87	200	184.5	218	508	710	SBWG-05-1SD	635 (598)
600	24	613	915	267	167	514.6	678	528	110	200	230	290	648	900	SBWG-06-1SD	981 (944)

() Standard

TT2-2U/2K

80 to 150mm

200 to 400mm

450 to 600mm

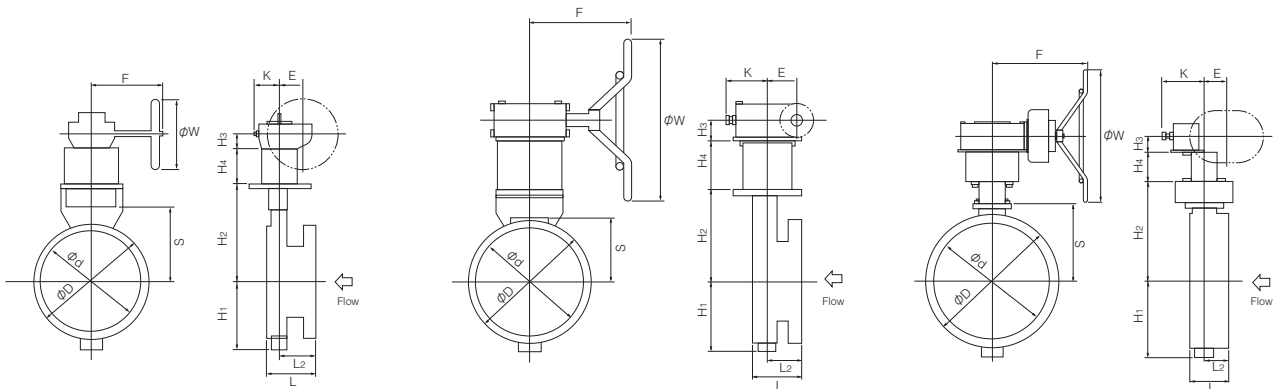

2U/2K Installation Direction

<p>Stem Side</p> <p>Flow</p> <p>Retainer Side</p>	<p>Stem Side</p> <p>Flow</p> <p>Retainer Side</p>	<p>Stem Side</p> <p>Flow</p> <p>Retainer Side</p>	<p>Stem Side</p> <p>Flow</p> <p>Retainer Side</p>
2UA / 2KA	2UB / 2KB	2UC / 2KC	2UD / 2KD

TT2 Applicable flange standard

■ 150Lb Wafer

Nominal size		ANSI, API/JPI		JIS			BS4504, DIN, ISO			
mm	inch	300Lb	150Lb	10K	16K, 20K	30K	PN10(NP10)	PN16(NP16)	PN25(NP25)	PN40(NP40)
80	3	T (D)	—	T (D)	T (D)	T (D)	T (D)	T (D)	T (D)	T (D)
100	4	T (D)	T (D)	T (D)	T (D)	T (D)	T (D)	T (D)	T (D)	T (D)
150	6	×	T (D)	T (D)	T (D)	×	T (D)	T (D)	×	×
200	8	×	T (D)	T (D)	T (D)	×	T (D)	T (D)	×	×
250	10	×	T (D)	T (D)	T (D)	×	T (D)	T (D)	×	×
300	12	×	T (D)	T	T	×	T (D)	T (D)	×	×
350	14	×	T (D)	T (D)	T (D)	×	T (D)	T (D)	×	×
400	16	×	T (D)	T (D)	T (D)	×	T (D)	T (D)	×	×
450	18	×	T	T	T	×	T	T	×	×
500	20	×	T	T	T	×	T	T	×	×
600	24	×	T	T	T	×	T	T	×	×

■ 300Lb Wafer

Nominal size		ANSI, API/JPI		JIS			BS4504, DIN, ISO			
mm	inch	300Lb	150Lb	10K	16K, 20K	30K	PN10(NP10)	PN16(NP16)	PN25(NP25)	PN40(NP40)
80	3	T (D)	—	T (D)	T (D)	T (D)	T (D)	T (D)	T (D)	T (D)
100	4	T (D)	T (D)	T (D)	T (D)	T (D)	T (D)	T (D)	T (D)	T (D)
150	6	T (D)	×	×	T (D)	T (D)	×	T (D)	T (D)	T (D)
200	8	T (D)	×	×	T (D)	T (D)	×	T (D)	T (D)	T (D)
250	10	T	×	×	T (D)	T (D)	×	T (D)	T (D)	T (D)
300	12	T	×	×	T	T	×	T (D)	T	T
350	14	T	×	×	T	T	×	T	T	T
400	16	T	×	×	T	T	×	T	T	T
450	18	T	×	×	T	×	×	T	T	T
500	20	T	×	×	T	×	×	T	T	T
600	24	T	×	×	T	×	×	T	T	T

T(D): With drill hole or tapping.
 T : With flange tapping
 — : No nominal diameter.
 × : Not applicable

Butterfly Valve
TRITEC
TT2
334A
302A/303Q
304A/304Q
302Y/304Y
304M (HLV)
507V/508V
DTM
846T/847T/847Q
841T/842T
700Z
700G/704G/705G
700GB
731P/732P/731Q/732Q
71LG
700E/700K/700S
704G/722F/720F
KRV
227P
907H/908H (MKT)
903C

TT2 Applicable flange standard

■150Lb Lugged

Nominal size		ANSI, API/JPI		JIS			BS4504, DIN, ISO			
mm	inch	300Lb	150Lb	10K	16K, 20K	30K	PN10(NP10)	PN16(NP16)	PN25(NP25)	PN40(NP40)
80	3	×	T (D)	×	×	×	×	×	×	×
100	4	T (D)	T (D)	T (D)	T (D)	T (D)	T (D)	T (D)	T (D)	T (D)
150	6	×	T (D)	T (D)	×	×	T (D)	T (D)	×	×
200	8	×	T (D)	×	×	×	T (D)	×	×	×
250	10	×	T (D)	T (D)	T (D)	×	T (D)	T (D)	×	×
300	12	×	T (D)	×	×	×	T (D)	T (D)	×	×
350	14	×	T (D)	×	×	×	×	×	×	×
400	16	×	T (D)	T (D)	T (D)	×	T (D)	T (D)	×	×
450	18	×	T	×	×	×	×	×	×	×
500	20	×	T	T	T	×	T	T	×	×
600	24	×	T	×	×	×	T	T	×	×

■300Lb Lugged

Nominal size		ANSI, API/JPI		JIS			BS4504, DIN, ISO			
mm	inch	300Lb	150Lb	10K	16K, 20K	30K	PN10(NP10)	PN16(NP16)	PN25(NP25)	PN40(NP40)
80	3	T (D)	×	T (D)	T (D)	T (D)	T (D)	T (D)	T (D)	T (D)
100	4	T (D)	T (D)	T (D)	T (D)	T (D)	T (D)	T (D)	T (D)	T (D)
150	6	T (D)	×	×	T (D)	T (D)	×	×	×	×
200	8	T (D)	×	×	T (D)	T (D)	×	T (D)	T (D)	T (D)
250	10	T	×	×	×	×	×	×	×	×
300	12	T	×	×	T	T	×	×	T	T
350	14	T	×	×	×	×	×	×	×	×
400	16	T	×	×	×	×	×	×	×	×
450	18	T	×	×	×	×	×	×	×	×
500	20	T	×	×	×	×	×	×	×	×
600	24	T	×	×	×	×	×	×	×	×

T(D) : With drill hole or tapping.
 T : With flange tapping
 × : Not applicable

TT2 Applicable flange standard

■ 150Lb DFSP

Nominal size		ANSI, API/JPI		JIS			BS4504, DIN, ISO			
mm	inch	300Lb	150Lb	10K	16K, 20K	30K	PN10(NP10)	PN16(NP16)	PN25(NP25)	PN40(NP40)
80	3	×	D	×	×	×	×	×	×	×
100	4	×	T	×	×	×	×	×	×	×
150	6	×	T	×	×	×	×	×	×	×
200	8	×	T	×	×	×	×	×	×	×
250	10	×	T	×	×	×	×	×	×	×
300	12	×	T	×	×	×	×	×	×	×
350	14	×	T	×	×	×	×	×	×	×
400	16	×	T	×	×	×	×	×	×	×
450	18	×	T	×	×	×	×	×	×	×
500	20	×	T	×	×	×	×	×	×	×
600	24	×	T	×	×	×	×	×	×	×

■ 300Lb DFSP

Nominal size		ANSI, API/JPI		JIS			BS4504, DIN, ISO			
mm	inch	300Lb	150Lb	10K	16K, 20K	30K	PN10(NP10)	PN16(NP16)	PN25(NP25)	PN40(NP40)
80	3	T	×	×	×	×	×	×	×	×
100	4	T	×	×	×	×	×	×	×	×
150	6	T	×	×	×	×	×	×	×	×
200	8	T	×	×	×	×	×	×	×	×
250	10	T	×	×	×	×	×	×	×	×
300	12	T	×	×	×	×	×	×	×	×
350	14	T	×	×	×	×	×	×	×	×
400	16	T	×	×	×	×	×	×	×	×
450	18	T	×	×	×	×	×	×	×	×
500	20	T	×	×	×	×	×	×	×	×
600	24	T	×	×	×	×	×	×	×	×

D : With flange drilling
T : With flange tapping
× : Not applicable

* JIS, BS, DIN double-flange type main body not available.
Please consult with us regarding the appropriateness of JIS, BS and DIN piping in an ANSI or API/JPI main body.

Butterfly Valve
TRITEC
TT2
334A
302A/303Q
304A/304Q
302Y/304Y
304M (HLV)
507V/508V
DTM
846T/847T/847Q
841T/842T
700Z
700G/704G/705G
700GB
731P/732P/731Q/732Q
71LG
700E/700K/700S
704G/722F/720F
KRV
227P
907H/908H (MKT)
903C

TT2 Wafer Type Piping Bolts and Nuts Sizes

■ Wafer Type 150Lb

Nominal size		ASME B16.5 150Lb, JPI-7S-15 150Lb			10K		
mm	inch	Setting Bolts	Long Bolts	No. of Nuts	Setting Bolts	Long Bolts	No. of Nuts
80	3	—	4-5/8-11UNC×160	8	8-M16× 75(13× 8)	4-M16×145	16
100	4	8-5/8-11UNC× 85(13× 8)	4-5/8-11UNC×160	16	8-M16× 75(13× 8)	4-M16×145	16
150	6	8-3/4-10UNC× 95(17×11)	4-3/4-10UNC×175	16	8-M20× 85(17×11)	4-M20×170	16
200	8	8-3/4-10UNC× 95(17×11)	4-3/4-10UNC×185	16	8-M20× 85(17×11)	8-M20×180	24
250	10	8-7/8- 9UNC×100(19×12)	8-7/8- 9UNC×205	24	8-M22× 95(19×12)	8-M22×190	24
300	12	8-7/8- 9UNC×100(19×12)	8-7/8- 9UNC×220	24	8-M22× 95(19×12)	12-M22×200	32
350	14	8- 1-8UNC×115(21×14)	8- 1-8UNC×245	24	8-M22× 95(19×12)	12-M22×215	32
400	16	8- 1-8UNC×125(21×14)	12- 1-8UNC×260	32	8-M24×120(21×14)	12-M24×240	32
450	18	8- 1 1/8-8UN×135(24×16)	12-1 1/8-8UN×285	32	8-M24×110(21×14)	16-M24×250	40
500	20	8- 1 1/8-8UN×135(24×16)	16-1 1/8-8UN×300	40	8-M24×110(21×14)	16-M24×260	40
600	24	8- 1 1/4-8UN×145(24×16)	16-1 1/4-8UN×345	40	8-M30×125(24×16)	20-M30×320	48

Nominal size		16K			20K		
mm	inch	Setting Bolts	Long Bolts	No. of Nuts	Setting Bolts	Long Bolts	No. of Nuts
80	3	8-M20× 85(17×11)	4-M20×160	16	8-M20× 85(17×11)	4-M20×160	16
100	4	8-M20× 85(17×11)	4-M20×170	16	8-M20× 85(17×11)	4-M20×170	16
150	6	8-M22× 95(19×12)	8-M22×175	24	8-M22× 95(19×12)	8-M22×190	24
200	8	8-M22× 95(19×12)	8-M22×190	24	8-M22×105(19×12)	8-M22×200	24
250	10	8-M24×100(21×14)	8-M24×210	24	8-M24×110(21×14)	8-M24×220	24
300	12	8-M24×100(21×14)	12-M24×220	32	8-M24×110(21×14)	12-M24×230	32
350	14	8-M30(P3)×125(24×16)	12-M30(P3)×250	32	8-M30(P3)×135(24×16)	12-M30(P3)×260	32
400	16	8-M30(P3)×135(24×16)	12-M30(P3)×275	32	8-M30(P3)×145(24×16)	12-M30(P3)×285	32
450	18	8-M30(P3)×135(24×16)	16-M30(P3)×285	40	8-M30(P3)×145(24×16)	16-M30(P3)×300	40
500	20	8-M30(P3)×135(24×16)	16-M30(P3)×300	40	8-M30(P3)×145(24×16)	16-M30(P3)×315	40
600	24	8-M36(P3)×155(30×20)	20-M36(P3)×355	48	8-M36(P3)×165(30×20)	20-M36(P3)×365	48

Note: Bolt/Nut material: SNB7/S45C

Please use a nut with a height that is 100% of the screw diameter.

The bold length calculation is based on use of a 4.5 mm thick spiral gasket.

The flange thickness calculation is based on the standard steel flange thickness.

Quantities shown are for one valve.

Examples

Setting bolts: 8 - M16 × 75 (13 × 8)

Long bolts: 4 - M16 × 145

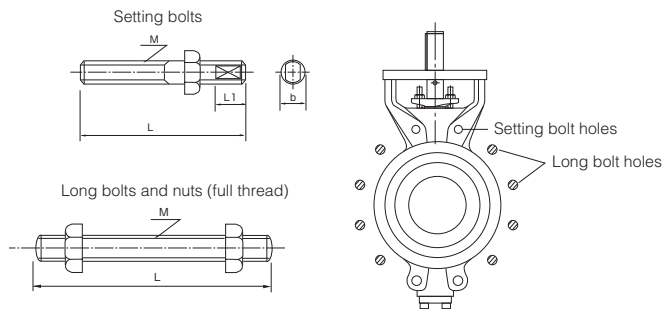

TT2 Wafer Type Piping Bolts and Nuts Sizes

■ Wafer Type 150Lb

Nominal size		DIN NP10, BS4504 PN10, ISO7005-1 PN10			DIN NP16, BS4504 PN16, ISO7005-1 PN16		
mm	inch	Setting Bolts	Long Bolts	No. of Nuts	Setting Bolts	Long Bolts	No. of Nuts
80	3	8-M16× 75(13× 8)	4-M16×145	16	8-M16× 75(13× 8)	4-M16×145	16
100	4	8-M16× 75(13× 8)	4-M16×155	16	8-M16× 75(13× 8)	4-M16×155	16
150	6	8-M20× 85(17×11)	4-M20×170	16	8-M20× 85(17×11)	4-M20×170	16
200	8	8-M20× 85(17×11)	4-M20×180	16	8-M20× 85(17×11)	8-M20×180	24
250	10	8-M20× 95(17×11)	8-M20×190	24	8-M24×100(21×14)	8-M24×200	24
300	12	8-M20× 95(17×11)	8-M20×210	24	8-M24×100(21×14)	8-M24×220	24
350	14	8-M20× 95(17×11)	12-M20×210	32	8-M24×110(21×14)	12-M24×230	32
400	16	8-M24×110(21×14)	12-M24×230	32	8-M27×125(22×14)	12-M27×250	32
450	18	8-M24×110(21×14)	16-M24×250	40	8-M27×125(22×14)	16-M27×265	40
500	20	8-M24×110(21×14)	16-M24×260	40	8-M30×125(24×16)	16-M30×285	40
600	24	8-M27×125(22×14)	16-M27×310	40	8-M33×145(27×18)	16-M33×350	40

■ Wafer Type 300Lb

Nominal size		ASME B16.5 300Lb, JPI-7S-15 300Lb			JIS20K		
mm	inch	Setting Bolts	Long Bolts	No. of Nuts	Setting Bolts	Long Bolts	No. of Nuts
80	3	8-3/4-10UNC×95(17×11)	4-3/4-10UNC×175	16	8-M20× 85(17×11)	4-M20×160	16
100	4	8-3/4-10UNC×95(17×11)	4-3/4-10UNC×185	16	8-M20× 85(17×11)	4-M20×170	16
150	6	8-3/4-10UNC×95(17×11)	8-3/4-10UNC×200	24	8-M22× 95(19×12)	8-M22×190	24
200	8	8-7/8-9UNC×115(19×12)	8- 7/8-9UNC×235	24	8-M22×105(19×12)	8-M22×200	24
250	10	8- 1-8UNC×125(21×14)	12- 1-8UNC×260	32	8-M24×110(21×14)	8-M24×230	24
300	12	8-1 1/8-8UN×135(24×16)	12-1 1/8-8UN×285	32	8-M24×120(21×14)	12-M24×240	32
350	14	8-1 1/8-8UN×135(24×16)	16-1 1/8-8UN×315	40	8-M30(P3)×125(24×16)	12-M30(P3)×285	32
400	16	8-1 1/4-8UN×145(24×16)	16-1 1/4-8UN×345	40	8-M30(P3)×135(24×16)	12-M30(P3)×315	32
450	18	8-1 1/4-8UN×145(24×16)	20-1 1/4-8UN×365	48	8-M30(P3)×135(24×16)	16-M30(P3)×335	40
500	20	8-1 1/4-8UN×155(24×16)	20-1 1/4-8UN×380	48	8-M30(P3)×135(24×16)	16-M30(P3)×350	40
600	24	8-1 1/2-8UN×185(30×20)	20-1 1/2-8UN×430	48	8-M36(P3)×165(30×20)	20-M36(P3)×385	48

Note: Bolt/Nut material: SNB7/S45C

Please use a nut with a height that is 100% of the screw diameter.

The bold length calculation is based on use of a 4.5 mm thick spiral gasket.

The flange thickness calculation is based on the standard steel flange thickness.

Quantities shown are for one valve.

Examples

Setting bolts: 8 - M16 × 75 (13 × 8)
 | | | | |
 N M L b L1

Long bolts: 4 - M16 × 145
 | | |
 N M L

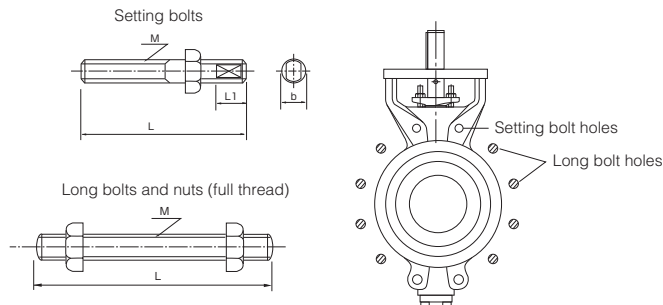

Butterfly Valve
TRITEC
TT2
334A
302A/303Q
304A/304Q
302Y/304Y
304M (HLV)
507V/508V
DTM
846T/847T/847Q
841T/842T
700Z
700G/704G/705G
700GB
731P/732P/731Q/732Q
71LG
700E/700K/700S
704G/722F/720F
KRV
227P
907H/908H (MKT)
903C

TT2 Full-lugged (fully-tapped) Piping Bolts and Nuts Sizes

■ Lugged Type 150Lb

Nominal size		ASME B16.5 150Lb, JPI-7S-15 150Lb		JIS10K		JIS16K	
mm	inch	Setting Bolts	No. of Nuts	Setting Bolts	No. of Nuts	Setting Bolts	No. of Nuts
80	3	8- 5/8-11UNC×85(13× 8)	8	—	—	—	—
100	4	16-5/8-11UNC×85(13× 8)	16	16-M16× 75(13× 8)	16	16 -M20×85(17×11)	16
150	6	16-3/4-10UNC×95(17×11)	16	16-M20× 85(17×11)	16	—	—
200	8	16-3/4-10UNC×95(17×11)	16	—	—	—	—
250	10	24-7/8-9UNC×100(19×12)	24	24-M22× 95(19×12)	24	24-M24×100(21×14)	24
300	12	24-7/8-9UNC×100(19×12)	24	—	—	—	—
350	14	24- 1-8UNC×115(21×14)	24	—	—	—	—
400	16	32- 1-8UNC×115(21×14)	32	32-M24×110(21×14)	32	32-M30(P3)×125(24×16)	32
450	18	32-1 1/8-8UN×135(24×16)	32	—	—	—	—
500	20	40-1 1/8-8UN×135(24×16)	40	40-M24×110(21×14)	40	40-M30(P3)×135(24×16)	40
600	24	40-1 1/4-8UN×145(24×16)	40	—	—	—	—

Nominal size		JIS20K		DIN NP10 BS4504 PN10, ISO7005-1 PN10		DIN NP16, BS4504 PN16, ISO7005-1 PN16	
mm	inch	Setting Bolts	No. of Nuts	Setting Bolts	No. of Nuts	Setting Bolts	No. of Nuts
80	3	—	—	—	—	—	—
100	4	16-M20× 85(17×11)	16	16-M16× 75(13× 8)	16	16-M16× 75(13× 8)	16
150	6	—	—	16-M20× 85(17×11)	16	16-M20× 85(17×11)	16
200	8	—	—	16-M20× 85(17×11)	16	—	—
250	10	24-M24×110(21×14)	24	24-M20× 95(17×11)	24	24-M24×100(21×14)	24
300	12	—	—	24-M20× 95(17×11)	24	24-M24×100(21×14)	24
350	14	—	—	—	—	—	—
400	16	32-M30(P3)×135(24×16)	32	32-M24×110(21×14)	32	32-M27×115(22×14)	32
450	18	—	—	—	—	—	—
500	20	40-M30(P3)×145(24×16)	40	40-M24×110(21×14)	40	40-M30×125(24×16)	40
600	24	—	—	40-M27×115(22×14)	40	40-M33×145(27×18)	40

Note: Bolt/Nut material: SNB7/S45C

Please use a nut with a height that is 100% of the screw diameter.

The bold length calculation is based on use of a 4.5 mm thick spiral gasket.

The flange thickness calculation is based on the standard steel flange thickness.

Quantities shown are for one valve.

Examples

Setting bolts: 8 - M16 × 75 (13 × 8)

|
|
|
|
|

N
M
L
b
L1

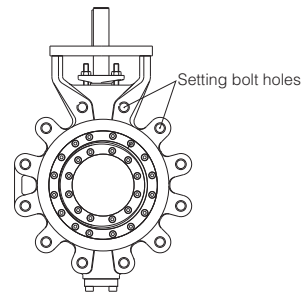
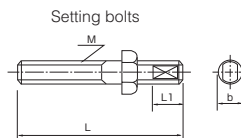

Butterfly Valve
TRITEC
TT2
334A
302A/303Q
304A/304Q
302Y/304Y
304M (HLV)
507V/508V
DTM
846T/847T/847Q
841T/842T
700Z
700G/704G/705G
700GB
731P/732P/731Q/732Q
71LG
700E/700K/700S
704G/722F/720F
KRV
227P
907H/908H (MKT)
903C

TT2 Full-lugged (fully-tapped) Piping Bolts and Nuts Sizes

■ Lugged Type 300Lb

Nominal size		ASME B16.5 300Lb, JPI-7S-15 300Lb		JIS20K		JIS30K	
mm	inch	Setting Bolts	No. of Nuts	Hexagon Bolts	No. of Nuts	Hexagon Bolts	No. of Nuts
80	3	16-3/4-10UNC× 95(17×11)	16	16-M20× 75(17×11)	16	16-M20× 85(17×11)	16
100	4	16-3/4-10UNC× 95(17×11)	16	16-M20× 85(17×11)	16	16-M22× 95(19×12)	16
150	6	24-3/4-10UNC× 95(17×11)	24	24-M22× 95(19×12)	24	24-M24×110(21×14)	24
200	8	24- 7/8-9UNC×115(19×12)	24	24-M22×105(19×12)	24	24-M24×120(21×14)	24
250	10	32- 1-8UNC×125(21×14)	32	—	—	—	—
300	12	32- 1 1/8-8UN×135(24×16)	32	32-M24×120(21×14)	32	32-M30(P3)×135(24×16)	32
350	14	40- 1 1/8-8UN×135(24×16)	40	—	—	—	—
400	16	40- 1 1/4-8UN×145(24×16)	40	—	—	—	—
450	18	48- 1 1/4-8UN×145(24×16)	48	—	—	—	—
500	20	48- 1 1/4-8UN×155(24×16)	48	—	—	—	—
600	24	48- 1 1/2-8UN×185(30×20)	48	—	—	—	—

Nominal size		DIN NP25, BS4504 PN25, ISO7005-5 PN25		DIN NP40, BS4504 PN40, ISO7005-5 PN40	
mm	inch	Setting Bolts	No. of Nuts	Hexagon Bolts	No. of Nuts
80	3	16-M16× 75(13× 8)	16	16-M16× 75(13× 8)	16
100	4	16-M20× 85(17×11)	16	16-M20× 85(17×11)	16
150	6	—	—	—	—
200	8	24-M24×110(21×14)	24	24-M27×115(22×14)	24
250	10	—	—	—	—
300	12	32-M27×115(22×14)	32	32-M30×125(24×16)	32
350	14	—	—	—	—
400	16	—	—	—	—
450	18	—	—	—	—
500	20	—	—	—	—
600	24	—	—	—	—

Note: Bolt/Nut material: SNB7/S45C

Please use a nut with a height that is 100% of the screw diameter.

The bolt length calculation is based on use of a 4.5 mm thick spiral gasket.

The flange thickness calculation is based on the standard steel flange thickness.

Quantities shown are for one valve.

Examples

Setting bolts: 8 - M16 × 75 (13 × 8)

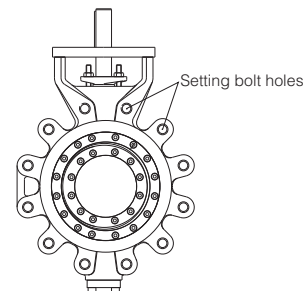
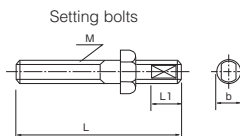

TT2 Double-flanged (short-pattern) Piping Bolts and Nuts Sizes

■ 150 Lb, Double-flanged, Short-pattern Type

Nominal size		ASME B16.5 150Lb, JPI-7S-15 150Lb		
mm	inch	Setting Bolts	Hexagon Bolts	No. of Nuts
80	3	—	8-5/8-11UNC× 80	8
100	4	4-5/8-11UNC×70(13× 8)	12-5/8-11UNC× 80	16
150	6	4-3/4-10UNC×85(17×11)	12-3/4-10UNC× 95	16
200	8	4-3/4-10UNC×85(17×11)	12-3/4-10UNC× 95	16
250	10	4-7/8-9UNC×100(19×12)	20-7/8-9UNC×100	24
300	12	4-7/8-9UNC×100(19×12)	20-7/8-9UNC×100	24
350	14	4- 1-8UNC×115(21×14)	20- 1-8UNC×115	24
400	16	4- 1-8UNC×115(21×14)	28- 1-8UNC×115	32
450	18	4-1 1/8-8UN×125(24×16)	28-1 1/8-8UN×130	32
500	20	4-1 1/8-8UN×125(24×16)	36-1 1/8-8UN×130	40
600	24	4-1 1/4-8UN×135(24×16)	36-1 1/4-8UN×145	40

■ 300Lb, Double-flanged, Short-pattern Type

Nominal size		ASME B16.5 300Lb, JPI-7S-15 300Lb		
mm	inch	Setting Bolts	Hexagon Bolts	No. of Nuts
80	3	4-3/4-10UNC×85(17×11)	12-3/4-10UNC× 95	16
100	4	4-3/4-10UNC×85(17×11)	12-3/4-10UNC× 95	16
150	6	4-3/4-10UNC×95(17×11)	20-3/4-10UNC×105	24
200	8	4-7/8-9UNC×100(19×12)	20-7/8-9UNC×120	24
250	10	4- 1-8UNC×125(21×14)	28- 1-8UNC×140	32
300	12	4-1 1/8-8UN×135(24×16)	28-1 1/8-8UN×150	32
350	14	8-1 1/8-8UN×135(24×16)	32-1 1/8-8UN×150	40
400	16	8-1 1/4-8UN×145(24×16)	32-1 1/4-8UN×165	40
450	18	8-1 1/4-8UN×145(24×16)	40-1 1/4-8UN×165	48
500	20	8-1 1/4-8UN×145(24×16)	40-1 1/4-8UN×175	48
600	24	8-1 1/2-8UN×175(30×20)	40-1 1/2-8UN×195	48

Note: Bolt/Nut material: SNB7/S45C

Please use a nut with a height that is 100% of the screw diameter.

The bold length calculation is based on use of a 4.5 mm thick spiral gasket.

The flange thickness calculation is based on the standard steel flange thickness.

Quantities shown are for one valve.

Examples

Setting bolts: 8 - M16 × 75 (13 × 8)

|
|
|
|
|

N
M
L
b
L1

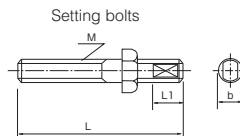

Hexagon bolts : 4 - M30 × 95

|
|
|

N
M
L

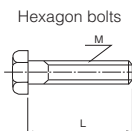

Butterfly Valve
TRITEC
TT2
334A
302A/303Q
304A/304Q
302Y/304Y
304M (HLV)
507V/508V
DTM
846T/847T/847Q
841T/842T
700Z
700G/704G/705G
700GB
731P/732P/731Q/732Q
71LG
700E/700K/700S
704G/722F/720F
KRV
227P
907H/908H (MKT)
903C

TT2 Piping gasket

* In case of spiral gasket

For API, JPI, ANSI flange Any standard gaskets with inner/outer ring can be used.

For JIS, BS, DIN flange Use special spiral gasket shown below.

●TT2 Commercially available spiral gasket conformity chart (with inner and outer ring)

Nominal size		ASME/JPI		JIS			BS4504			
mm	inch	150Lb	300Lb	10K	16/20K	30K	PN10	PN16	PN25	PN40
80	3	○	○	×	×	×	×	×	×	×
100	4	○	○	×	×	×	×	×	×	×
150	6	○	○	○	○	×	○	○	○	○
200	8	○	○	○	○	×	○	○	○	○
250	10	○	○	○	×	×	○	○	○	○
300	12	○	○	○	×	×	○	○	○	○
350	14	○	○	○	×	×	○	○	○	○
400	16	○	○	○	×	×	○	○	○	○
450	18	○	○	○	○	—	○	○	○	○
500	20	○	○	○	○	—	○	○	○	○
600	24	○	○	○	○	—	○	○	○	○

* Please use the following special spiral gaskets for the portions marked in "X" in the conformity chart above.

●TT2 Special spiral gasket flange size

Nominal size		JIS10K				JIS16/20K				JIS30K				BS4504						
		D1	D2	D3	D4	D1	D2	D3	D4	D1	D2	D3	D4	D1	D2	D3	D4			
mm	inch	BS4504																		
		PN10				PN16				PN25				PN40						
80	3	91	111	125	134	89	111	126	140	80	111	125	150	84	111	126	144	144	144	144
100	4	115	130	146	159	115	130	153	165	104	130	153	172	108	130	153	164	164	170	170
150	6	—	—	—	—	—	—	—	—	153	176	202	249	—	—	—	—	—	—	—
200	8	—	—	—	—	—	—	—	—	202	227	259	294	—	—	—	—	—	—	—
250	10	—	—	—	—	268	281	321	354	251	282	322	360	—	—	—	—	—	—	—
300	12	—	—	—	—	319	333	372	404	300	334	374	418	—	—	—	—	—	—	—
350	14	—	—	—	—	356	370	410	450	336	367	407	463	—	—	—	—	—	—	—
400	16	—	—	—	—	407	417	467	508	383	418	468	524	—	—	—	—	—	—	—

